

```
{
FILE* sfile;
int count = 0;

sfile = fopen("fi]

if( sfile == NULL)
{
    return -1;
}

while (1)
{
    char c;
    c = fgetc(
    if(c == EOF
    {
        bre
    }
    else
    {
    }
}

return c
```

TriCore v2.1

C Compiler, Assembler, Linker User's Manual

A publication of
Altium BV
Documentation Department
Copyright © 2002–2004 Altium BV

All rights reserved. Reproduction in whole or part is prohibited
without the written consent of the copyright owner.

TASKING is a brand name of Altium Limited.

The following trademarks are acknowledged:

FLEXIm is a registered trademark of Macrovision Corporation.

Intel is a trademark of Intel Corporation.

Motorola is a registered trademark of Motorola, Inc.

MS-DOS and Windows are registered trademarks of Microsoft Corporation.

SUN is a trademark of Sun Microsystems, Inc.

UNIX is a registered trademark of X/Open Company, Ltd.

All other trademarks are property of their respective owners.

Data subject to alteration without notice.

<http://www.tasking.com>

<http://www.altium.com>

The information in this document has been carefully reviewed and is believed to be accurate and reliable. However, Altium assumes no liabilities for inaccuracies in this document. Furthermore, the delivery of this information does not convey to the recipient any license to use or copy the software or documentation, except as provided in an executed license agreement covering the software and documentation.

Altium reserves the right to change specifications embodied in this document without prior notice.

CONTENTS

TABLE OF CONTENTS

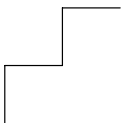

CONTENTS

SOFTWARE INSTALLATION AND CONFIGURATION 1-1

1.1	Introduction	1-3
1.2	Software Installation	1-3
1.2.1	Installation for Windows	1-3
1.2.2	Installation for Linux	1-4
1.2.3	Installation for UNIX Hosts	1-6
1.3	Software Configuration	1-7
1.3.1	Configuring the Embedded Development Environment	1-7
1.3.2	Configuring the Command Line Environment	1-9
1.4	Licensing TASKING Products	1-12
1.4.1	Obtaining License Information	1-12
1.4.2	Installing Node-Locked Licenses	1-13
1.4.3	Installing Floating Licenses	1-14
1.4.4	Modifying the License File Location	1-16
1.4.5	How to Determine the Hostid	1-17
1.4.6	How to Determine the Hostname	1-17

GETTING STARTED 2-1

2.1	Introduction	2-3
2.2	Working With Projects in EDE	2-7
2.3	Start EDE	2-8
2.4	Using the Sample Projects	2-9
2.5	Create a New Project Space with a Project	2-9
2.6	Set Options for the Tools in the Toolchain	2-14
2.7	Build your Application	2-16
2.8	How to Build Your Application on the Command Line	2-17
2.9	Debug getstart.elf	2-18

TRICORE C LANGUAGE 3-1

3.1	Introduction	3-3
3.2	Data Types	3-3
3.2.1	Fundamental Data Types	3-3
3.2.2	Fractional Data Types	3-5

3.2.3	Bit Data Type	3-6
3.2.4	Packed Data Types	3-8
3.3	Memory Qualifiers	3-10
3.3.1	Declare a Data Object in a Special Part of Memory . . .	3-10
3.3.2	Declare a Data Object at an Absolute Address: __at() and __atbit()	3-13
3.4	Data Type Qualifiers	3-15
3.4.1	Circular Buffers: __circ	3-15
3.4.2	Declare an SFR Bit field: __sfrbit16 and __sfrbit32	3-16
3.5	Intrinsic Functions	3-18
3.6	Using Assembly in the C Source: __asm()	3-19
3.7	Controlling the Compiler: Pragmas	3-25
3.8	Predefined Macros	3-28
3.9	Functions	3-29
3.9.1	Inlining Functions: inline	3-29
3.9.2	Interrupt and Trap Functions	3-31
3.9.2.1	Defining an Interrupt Service Routine	3-32
3.9.2.2	Defining a Trap Service Routine	3-33
3.9.2.3	Defining a Trap Service Routine Class 6: __syscallfunc()	3-34
3.9.2.4	Enabling Interrupt Requests: __enable_, __bistr_0)	3-36
3.9.3	Function Calling Modes: __indirect	3-37
3.9.4	Parameter Passing and the Stack Model: __stackparm	3-37
3.10	Compiler Generated Sections	3-41
3.11	Switch Statement	3-44
3.12	Libraries	3-45
3.12.1	Overview of Libraries	3-46
3.12.2	Printf and Scanf Formatting Routines	3-46
3.12.3	Rebuilding Libraries	3-48

TRICORE ASSEMBLY LANGUAGE

4-1

4.1	Introduction	4-3
4.2	Assembly Syntax	4-3
4.3	Assembler Significant Characters	4-4
4.4	Operands	4-5

4.4.1	Operands and Addressing Modes	4-5
4.4.2	PCP Addressing Modes	4-8
4.5	Symbol Names	4-8
4.6	Assembly Expressions	4-9
4.6.1	Numeric Constants	4-10
4.6.2	Strings	4-11
4.6.3	Expression Operators	4-12
4.7	Built-in Assembly Functions	4-14
4.8	Assembler Directives and Controls	4-17
4.8.1	Overview of Assembler Directives	4-18
4.8.2	Overview of Assembler Controls	4-21
4.9	Working with Sections	4-22
4.10	Macro Operations	4-24
4.10.1	Defining a Macro	4-24
4.10.2	Calling a Macro	4-25
4.10.3	Using Operators for Macro Arguments	4-27
4.10.4	Using the .DUP, .DUPA, .DUPC, .DUPF Directives as Macros	4-31
4.10.5	Conditional Assembly: .IF, .ELIF and .ELSE Directives .	4-31

USING THE COMPILER **5-1**

5.1	Introduction	5-3
5.2	Compilation Process	5-4
5.3	Compiler Optimizations	5-5
5.3.1	Optimize for Size or Speed	5-9
5.4	Calling the Compiler	5-10
5.5	How the Compiler Searches Include Files	5-15
5.6	Compiling for Debugging	5-16
5.7	C Code Checking: MISRA C	5-16
5.8	C Compiler Error Messages	5-19

USING THE ASSEMBLER **6-1**

6.1	Introduction	6-3
6.2	Assembly Process	6-3
6.3	Assembler Optimizations	6-4
6.4	Calling the Assembler	6-5
6.5	How the Assembler Searches Include Files	6-8
6.6	Generating a List File	6-8
6.7	Assembler Error Messages	6-9

USING THE LINKER **7-1**

7.1	Introduction	7-3
7.2	Linking Process	7-4
7.2.1	Phase 1: Linking	7-6
7.2.2	Phase 2: Locating	7-7
7.2.3	Linker Optimizations	7-9
7.3	Calling the Linker	7-11
7.4	Linking with Libraries	7-14
7.4.1	Specifying Libraries to the Linker	7-15
7.4.2	How the Linker Searches Libraries	7-16
7.4.3	How the Linker Extracts Objects from Libraries	7-17
7.5	Incremental Linking	7-18
7.6	Linking the C Startup Code	7-18
7.7	Controlling the Linker with a Script	7-20
7.7.1	Purpose of the Linker Script Language	7-20
7.7.2	EDE and LSL	7-21
7.7.3	Structure of a Linker Script File	7-22
7.7.4	The Architecture Definition: Self-Designed Cores	7-25
7.7.5	The Derivative Definition: Self-Designed Processors	7-29
7.7.6	The Memory Definition: Defining External Memory	7-31
7.7.7	The Section Layout Definition: Locating Sections	7-33
7.7.8	The Processor Definition: Using Multi-Processor Systems	7-37
7.8	Linker Labels	7-38
7.9	Generating a Map File	7-40

7.10	Linker Error Messages	7-41
------	-----------------------------	------

USING THE UTILITIES **8-1**

8.1	Introduction	8-3
8.2	Control Program	8-4
8.2.1	Calling the Control Program	8-4
8.3	Make Utility	8-9
8.3.1	Calling the Make Utility	8-11
8.3.2	Writing a Makefile	8-12
8.4	Archiver	8-23
8.4.1	Calling the Archiver	8-23
8.4.2	Examples	8-26

INDEX

CONTENTS

MANUAL PURPOSE AND STRUCTURE

Windows Users

The documentation explains and describes how to use the TriCore toolchain to program a TriCore DSP. The documentation is primarily aimed at Windows users. You can use the tools either with the graphical Embedded Development Environment (EDE) or from the command line in a command prompt window.

UNIX Users

For UNIX the toolchain works the same as it works for the Windows command line.

Directory paths are specified in the Windows way, with back slashes as in `.\include`. Simply replace the back slashes by forward slashes for use with UNIX: `./include`.

Some characters have a special meaning in a UNIX shell. In such cases you must escape the special characters. For example, `'-?'` must be specified as `'-\?'` in some shells. See your UNIX documentation for more information.

Structure

The toolchain documentation consists of a User's Manual (this manual) which includes a Getting Started section and a separate Reference Manual.

First you need to install the software. This is described in Chapter 1, *Software Installation and Configuration*

After installation you are ready to follow the *Getting Started* in Chapter 2.

Next, move on with the other chapters which explain how to use the compiler, assembler, linker and the various utilities.

Once you are familiar with these tools, you can use the Reference Manual to lookup specific options and details to make full use of the TriCore toolchain.

SHORT TABLE OF CONTENTS

Chapter 1: Software Installation and Configuration

Guides you through the installation of the software. Describes the most important settings, paths and filenames that you must specify to get the package up and running.

Chapter 2: Getting Started

Overview of the toolchain and its individual elements. Describes the relation between the toolchain and specific features of the TriCore. Explains step-by-step how to write, compile, assemble and debug your application. Teaches how you can use projects to organize your files.

Chapter 3: TriCore C Language

The TASKING TriCore C compiler is fully compatible with ISO-C. This chapter describes the specific TriCore features of the C language, including language extensions that are not standard in ISO-C. For example, pragmas are a way to control the compiler from within the C source.

Chapter 4: TriCore Assembly Language

Describes the specific features of the TriCore assembly language as well as 'directives', which are pseudo instructions that are interpreted by the assembler.

Chapter 5: Using the Compiler

Describes how you can use the compiler. An extensive overview of all options is included in the Reference Manual.

Chapter 6: Using the Assembler

Describes how you can use the assembler. An extensive overview of all options is included in the Reference Manual.

Chapter 7: Using the Linker

Describes how you can use the linker. An extensive overview of all options is included in the Reference Manual.

Chapter 8: Using the Utilities

Describes several utilities and how you can use them to facilitate various tasks. The following utilities are included: control program, make utility and archiver.

CONVENTIONS USED IN THIS MANUAL

Notation for syntax

The following notation is used to describe the syntax of command line input:

bold Type this part of the syntax literally.

italics Substitute the italic word by an instance. For example:

filename

Type the name of a file in place of the word *filename*.

{ } Encloses a list from which you must choose an item.

[] Encloses items that are optional. For example

ctc [-?]

Both **ctc** and **ctc -?** are valid commands.

| Separates items in a list. Read it as OR.

... You can repeat the preceding item zero or more times.

,... You can repeat the preceding item zero or more times, separating each item with a comma.

Example

ctc [*option*]... *filename*

You can read this line as follows: enter the command **ctc** with or without an option, follow this by zero or more options and specify a *filename*. The following input lines are all valid:

```
ctc test.c
ctc -g test.c
ctc -g -E test.c
```

Not valid is:

```
ctc -g
```

According to the syntax description, you have to specify a filename.

Icons

The following illustrations are used in this manual:



Note: notes give you extra information.



Warning: read the information carefully. It prevents you from making serious mistakes or from losing information.



This illustration indicates actions you can perform with the mouse. Such as EDE menu entries and dialogs.



Command line: type your input on the command line.



Reference: follow this reference to find related topics.

RELATED PUBLICATIONS

C Standards

- C A Reference Manual (fifth edition) by Samuel P. Harbison and Guy L. Steele Jr. (2002, Prentice Hall)
- The C Programming Language (second edition) by B. Kernighan and D. Ritchie (1988, Prentice Hall)
- ISO/IEC 9899:1999(E), Programming languages – C [ISO/IEC]
More information on the standards can be found at
<http://www.ansi.org>
- DSP–C, An Extension to ISO/IEC 9899:1999(E),
Programming languages – C [TASKING, TK0071–14]

MISRA C

- Guidelines for the Use of the C Language in Vehicle Based Software [MISRA]
See also <http://www.misra.org.uk>

TASKING Tools

- TriCore C Compiler, Assembler, Linker Reference Manual [TASKING, MB060–024–00–00]
- TriCore C++ Compiler User's Manual [TASKING, MA60–012–00–00]
- TriCore CrossView Pro Debugger User's Manual [TASKING, MA060–043–00–00]

TriCore

- TriCore 1 Unified Processor Core v1.3 Architecture Manual, Doc v1.3.3 [2002–09, Infineon]
- TriCore2 Architecture Overview Handbook [2002, Infineon]
- TriCore Embedded Application Binary Interface [2000, Infineon]

MANUAL STRUCTURE

CHAPTER

1

SOFTWARE INSTALLATION AND CONFIGURATION

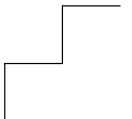

1 | CHAPTER

1.1 INTRODUCTION

This chapter guides you through the procedures to install the software on a Windows system or on a Linux or UNIX host.

The software for Windows has two faces: a graphical interface (Embedded Development Environment) and a command line interface. The Linux and UNIX software has only a command line interface.

After the installation, it is explained how to configure the software and how to install the license information that is needed to actually use the software.

1.2 SOFTWARE INSTALLATION

1.2.1 INSTALLATION FOR WINDOWS

1. Start Windows 95/98/XP/NT/2000, if you have not already done so.
2. Insert the CD-ROM into the CD-ROM drive.

If the TASKING Showroom dialog box appears, proceed with Step 5.

3. Click the **Start** button and select **Run...**
4. In the dialog box type **d:\setup** (substitute the correct drive letter for your CD-ROM drive) and click on the **OK** button.

The TASKING Showroom dialog box appears.

5. Select a product and click on the **Install** button.
6. Follow the instructions that appear on your screen.



You can find your serial number on the invoice, delivery note, or picking slip delivered with the product.

7. License the software product as explained in section 1.4, *Licensing TASKING Products*.

1.2.2 INSTALLATION FOR LINUX

Each product on the CD-ROM is available as an RPM package, Debian package and as a gzipped tar file. For each product the following files are present:

```
SWproduct-version-RPMrelease.i386.rpm
swproduct_version-release_i386.deb
SWproduct-version.tar.gz
```

These three files contain exactly the same information, so you only have to install one of them. When your Linux distribution supports RPM packages, you can install the `.rpm` file. For a Debian based distribution, you can use the `.deb` file. Otherwise, you can install the product from the `.tar.gz` file.

RPM Installation

1. In most situations you have to be "root" to install RPM packages, so either login as "root", or use the **su** command.
2. Insert the CD-ROM into the CD-ROM drive. Mount the CD-ROM on a directory, for example `/cdrom`. See the Linux manual pages about **mount** for details.
3. Go to the directory on which the CD-ROM is mounted:

```
cd /cdrom
```

4. To install or upgrade all products at once, issue the following command:

```
rpm -U SW*.rpm
```

This will install or upgrade all products in the default installation directory `/usr/local`. Every RPM package will create a single directory in the installation directory.

The RPM packages are 'relocatable', so it is possible to select a different installation directory with the **--prefix** option. For instance when you want to install the products in `/opt`, use the following command:

```
rpm -U --prefix /opt SW*.rpm
```



For Red Hat 6.0 users: The **--prefix** option does not work with RPM version 3.0, included in the Red Hat 6.0 distribution. Please upgrade to RPM version 3.0.3 or higher, or use the `.tar.gz` file installation described in the next section if you want to install in a non-standard directory.

Debian Installation

1. Login as a user.

Be sure you have read, write and execute permissions in the installation directory. Otherwise, login as "root" or use the **su** command.

2. Insert the CD-ROM into the CD-ROM drive. Mount the CD-ROM on a directory, for example `/cdrom`. See the Linux manual pages about **mount** for details.

3. Go to the directory on which the CD-ROM is mounted:

```
cd /cdrom
```

4. To install or upgrade all products at once, issue the following command:

```
dpkg -i sw*.deb
```

This will install or upgrade all products in a subdirectory of the default installation directory `/usr/local`.

Tar.gz Installation

1. Login as a user.

Be sure you have read, write and execute permissions in the installation directory. Otherwise, login as "root" or use the **su** command.

2. Insert the CD-ROM into the CD-ROM drive. Mount the CD-ROM on a directory, for example `/cdrom`. See the Linux manual pages about **mount** for details.

3. Go to the directory on which the CD-ROM is mounted:

```
cd /cdrom
```

4. To install the products from the `.tar.gz` files in the directory `/usr/local`, issue the following command for each product:

```
tar xzf SWproduct-version.tar.gz -C /usr/local
```

Every `.tar.gz` file creates a single directory in the directory where it is extracted.

1.2.3 INSTALLATION FOR UNIX HOSTS

1. Login as a user.

Be sure you have read, write and execute permissions in the installation directory. Otherwise, login as "root" or use the **su** command.

If you are a first time user, decide where you want to install the product. By default it will be installed in **/usr/local**.

2. Insert the CD-ROM into the CD-ROM drive and mount the CD-ROM on a directory, for example **/cdrom**.

Be sure to use an ISO 9660 file system with Rock Ridge extensions enabled. See the UNIX manual pages about **mount** for details.

3. Go to the directory on which the CD-ROM is mounted:

```
cd /cdrom
```

4. Run the installation script:

```
sh install
```

Follow the instructions appearing on your screen.

First a question appears about where to install the software. The default answer is **/usr/local**.

On some hosts the installation script asks if you want to install SW000098, the Flexible License Manager (FLEXlm). If you do not already have FLEXlm on your system, you must install it otherwise the product will not work on those hosts. See section 1.4, *Licensing TASKING Products*.

If the script detects that the software has been installed before, the following messages appear on the screen:

```
*** WARNING ***
SWxxxxxx xxxx.xxxx already installed.
Do you want to REINSTALL? [y,n]
```

Answering **n** (no) to this question causes installation to abort and the following message being displayed:

```
=> Installation stopped on user request <=
```

Answer **y** (yes) to continue with the installation. The last message will be:

```
Installation of SWxxxxxxx xxxx.xxxx completed.
```

5. If you purchased a protected TASKING product, license the software product as explained in section 1.4, *Licensing TASKING Products*.

1.3 SOFTWARE CONFIGURATION

Now you have installed the software, you can configure both the Embedded Development Environment and the command line environment for Windows, Linux and UNIX.

1.3.1 CONFIGURING THE EMBEDDED DEVELOPMENT ENVIRONMENT

After installation on Windows, the Embedded Development Environment is automatically configured with default search paths to find the executables, include files and libraries. In most cases you can use these settings. To change the default settings, follow the next steps:

1. Double-click on the EDE icon on your desktop to start the Embedded Development Environment (EDE).
2. From the **Project** menu, select **Directories...**

The Directories dialog box appears.

3. Fill in the following fields:
 - In the **Executable Files Path** field, type the pathname of the directory where the executables are located. The default directory is `$(PRODDIR)\bin`.
 - In the **Include Files Path** field, add the pathnames of the directories where the compiler and assembler should look for include files. The default directory is `$(PRODDIR)\include`. Separate pathnames with a semicolon (;).

The first path in the list is the first path where the compiler and assembler look for include files. To change the search order, simply change the order of pathnames.

- In the **Library Files Path** field, add the pathnames of the directories where the linker should look for library files. The default directory is $\$(PRODDIR)\lib$. Separate pathnames with a semicolon (;).

The first path in the list is the first path where the linker looks for library files. To change the search order, simply change the order of pathnames.



Instead of typing the pathnames, you can click on the **Configure...** button.

A dialog box appears in which you can select and add directories, remove them again and change their order.

1.3.2 CONFIGURING THE COMMAND LINE ENVIRONMENT

To facilitate the invocation of the tools from the command line (either using a Windows command prompt or using Linux or UNIX), you can set *environment variables*.

You can set the following variables:

Environment Variable	Description
PATH	With this variable you specify the directory in which the executables reside (for example: <code>c:\ctc\bin</code>). This allows you to call the executables when you are not in the <code>bin</code> directory. Usually your system already uses the <code>PATH</code> variable for other purposes. To keep these settings, you need to add (rather than replace) the path. Use a semicolon (;) to separate pathnames.
CTCINC	With this variable you specify one or more additional directories in which the C compiler ctc looks for include files. The compiler first looks in these directories, then always looks in the default <code>include</code> directory relative to the installation directory.
ASTCINC	With this variable you specify one or more additional directories in which the assembler astc looks for include files. The assembler first looks in these directories, then always looks in the default <code>include</code> directory relative to the installation directory.
ASPCPINC	With this variable you specify one or more additional directories in which the assembler aspcp looks for include files. The assembler first looks in these directories, then always looks in the default <code>include</code> directory relative to the installation directory.
CCTCBIN	With this variable you specify the directory in which the control program cctc looks for the executable tools. The path you specify here should match the path that you specified for the <code>PATH</code> variable.
CCTCOPT	With this variable you specify options and/or arguments to each invocation of the control program cctc . The control program processes these arguments before the command line arguments.

Environment Variable	Description
LIBTC1V1_2 LIBTC1V1_3 LIBTC2	With this variable you specify one or more alternative directories in which the linker ltc looks for library files for a specific core. The linker first looks in these directories, then always looks in the default lib directory.
LM_LICENSE_FILE	With this variable you specify the location of the license data file. You only need to specify this variable if the license file is not on its default location (<code>c:\flexlm</code> for Windows, <code>/usr/local/flexlm/licenses</code> for UNIX).
TASKING_LIC_WAIT	If you set this variable, the tool will wait for a license to become available, if all licenses are taken. If you have not set this variable, the tool aborts with an error message. (Only useful with floating licenses)
TMPDIR	With this variable you specify the location where programs can create temporary files. Usually your system already uses this variable. In this case you do not need to change it.

Table 1-1: Environment variables

The following examples show how to set an environment variable using the **PATH** variable as an example.

Example for Windows 95/98

Add the following line to your `autoexec.bat` file:

```
set PATH=%path%;c:\ctc\bin
```



You can also type this line in a Command Prompt window but you will lose this setting after you close the window.

Example for Windows NT

1. Right-click on the **My Computer** icon on your desktop and select **Properties** from the menu.

The System Properties dialog appears.

2. Select the **Environment** tab.

3. In the list of **System Variables** select **Path**.
4. In the **Value** field, add the path where the executables are located to the existing path information. Separate pathnames with a semicolon (;). For example: `c:\ctc\bin`.
5. Click on the **Set** button, then click **OK**.

Example for Windows XP / 2000

1. Right-click on the **My Computer** icon on your desktop and select **Properties** from the menu.

The System Properties dialog appears.

2. Select the **Advanced** tab.
3. Click on the **Environment Variables** button.

The Environment Variables dialog appears.

4. In the list of **System variables** select **Path**.
5. Click on the **Edit** button.

The Edit System Variable dialog appears.

6. In the **Variable value** field, add the path where the executables are located to the existing path information. Separate pathnames with a semicolon (;). For example: `c:\ctc\bin`.
7. Click on the **OK** button to accept the changes and close the dialogs.

Example for UNIX

Enter the following line (C-shell):

```
setenv PATH $PATH:/usr/local/ctc/bin
```

1.4 LICENSING TASKING PRODUCTS

TASKING products are protected with license management software (FLEXlm). To use a TASKING product, you must install the license key provided by TASKING for the type of license purchased.

You can run TASKING products with a node-locked license or with a floating license. When you order a TASKING product determine which type of license you need (UNIX products only have a floating license).

Node-locked license (PC only)

This license type locks the software to one specific PC so you can use the product on that particular PC only.

Floating license

This license type manages the use of TASKING product licenses among users at one site. This license type does not lock the software to one specific PC or workstation but it requires a network. The software can then be used on any computer in the network. The license specifies the number of users who can use the software simultaneously. A system allocating floating licenses is called a **license server**. A license manager running on the license server keeps track of the number of users.

1.4.1 OBTAINING LICENSE INFORMATION

Before you can install a software license you must have a "License Key" containing the license information for your software product. If you have not received such a license key follow the steps below to obtain one. Otherwise, you can install the license.

Windows

1. Run the License Administrator during installation and follow the steps to **Request a license key from Altium by E-mail**.
2. E-mail the license request to your local TASKING sales representative. The license key will be sent to you by E-mail.

UNIX

1. If you need a floating license on UNIX, you must determine the hostid and hostname of the computer where you want to use the license manager. Also decide how many users will be using the product. See section 1.4.5, *How to Determine the Hostid* and section 1.4.6, *How to Determine the Hostname*.
2. When you order a TASKING product, provide the hostid, hostname and number of users to your local TASKING sales representative. The license key will be sent to you by E-mail.

1.4.2 INSTALLING NODE-LOCKED LICENSES

If you do not have received your license key, read section 1.4.1, *Obtaining License Information*, before continuing.

1. Install the TASKING software product following the installation procedure described in section 1.2.1, *Installation for Windows*, if you have not done this already.
2. Create a license file by importing a license key or create one manually:

Import a license key

During installation you will be asked to run the License Administrator. Otherwise, start the License Administrator (**licadmin.exe**) manually.

In the License Administrator follow the steps to **Import a license key received from Altium by E-mail**. The License Administrator creates a license file for you.

Create a license file manually

If you prefer to create a license file manually, create a file called "license.dat" in the `c:\flexlm` directory, using an ASCII editor and insert the license key information received by E-mail in this file. This file is called the "license file". If the directory `c:\flexlm` does not exist, create the directory.



If you wish to install the license file in a different directory, see section 1.4.4, *Modifying the License File Location*.



If you already have a license file, add the license key information to the existing license file. If the license file already contains any SERVER lines, you must use another license file. See section 1.4.4, *Modifying the License File Location*, for additional information.

The software product and license file are now properly installed.

1.4.3 INSTALLING FLOATING LICENSES

If you do not have received your license key, read section 1.4.1, *Obtaining License Information*, before continuing.

1. Install the TASKING software product following the installation procedure described earlier in this chapter on each computer or workstation where you will use the software product.
2. On each PC or workstation where you will use the TASKING software product the location of a license file must be known, containing the information of all licenses. Either create a local license file or point to a license file on a server:

Add a license key to a local license file

A local license file can reduce network traffic.

On Windows, you can follow the same steps to import a license key or create a license file manually, as explained in the previous section with the installation of a node-locked license.

On UNIX, you have to insert the license key manually in the license file. The default location of the license file `license.dat` is in directory `/usr/local/flexlm/licenses` for UNIX.



If you wish to install the license file in a different directory, see section 1.4.4, *Modifying the License File Location*.



If you already have a license file, add the license key information to the existing license file. If the license file already contains any SERVER lines, make sure that the number of SERVER lines and their contents match, otherwise you must use another license file. See section 1.4.4, *Modifying the License File Location*, for additional information.

Point to a license file on the server

Set the environment variable **LM_LICENSE_FILE** to "*port@host*", where *host* and *port* come from the SERVER line in the license file. On Windows, you can use the License Administrator to do this for you. In the License Administrator follow the steps to **Point to a FLEXlm License Server to get your licenses**.

3. If you already have installed FLEXlm v8.4 or higher (for example as part of another product) you can skip this step and continue with step 4. Otherwise, install SW000098, the Flexible License Manager (FLEXlm), on the license server where you want to use the license manager.



It is not recommended to run a license manager on a Windows 95 or Windows 98 machine. Use Windows XP, NT or 2000 instead, or use UNIX or Linux.

4. If FLEXlm has already been installed as part of a non-TASKING product you have to make sure that the **bin** directory of the FLEXlm product contains a copy of the **Tasking** daemon. This file part of the TASKING product installation and is present in the **flexlm** subdirectory of the toolchain. This file is also on every product CD that includes FLEXlm, in directory **licensing**.
5. On the license server also add the license key to the license file. Follow the same instructions as with "Add a license key to a local license file" in step 2.



See the FLEXlm PDF manual delivered with SW000098, which is present on each TASKING product CD, for more information.

1.4.4 MODIFYING THE LICENSE FILE LOCATION

The default location for the license file on Windows is:

```
c:\flexlm\license.dat
```

On UNIX this is:

```
/usr/local/flexlm/licenses/license.dat
```

If you want to use another name or directory for the license file, each user must define the environment variable **LM_LICENSE_FILE**.

If you have more than one product using the FLEXlm license manager you can specify multiple license files to the **LM_LICENSE_FILE** environment variable by separating each pathname (*lppath*) with a ';' (on UNIX ':'):

Example Windows:

```
set LM_LICENSE_FILE=c:\flexlm\license.dat;c:\license.txt
```

Example UNIX:

```
setenv LM_LICENSE_FILE
/usr/local/flexlm/licenses/license.dat:/myprod/license.txt
```

If the license file is not available on these hosts, you must set **LM_LICENSE_FILE** to *port@host*; where *host* is the host name of the system which runs the FLEXlm license manager and *port* is the TCP/IP port number on which the license manager listens.

To obtain the port number, look in the license file at *host* for a line starting with "SERVER". The fourth field on this line specifies the TCP/IP port number on which the license server listens. For example:

```
setenv LM_LICENSE_FILE 7594@elliott
```



See the FLEXlm PDF manual delivered with SW000098, which is present on each TASKING product CD, for detailed information.

1.4.5 HOW TO DETERMINE THE HOSTID

The hostid depends on the platform of the machine. Please use one of the methods listed below to determine the hostid.

Platform	Tool to retrieve hostid	Example hostid
HP-UX	lanscan (use the station address without the leading '0x')	0000F0050185
Linux	hostid	11ac5702
SunOS/Solaris	hostid	170a3472
Windows	licadmin (License Administrator, or use lmhostid)	0060084dfbe9

Table 1-2: Determine the hostid

On Windows, the License Administrator (**licadmin**) helps you in the process of obtaining your license key.



If you do not have the program **licadmin** you can download it from our Web site at: <http://www.tasking.com/support/flexlm/licadmin.zip> . It is also on every product CD that includes FLEXlm, in directory **licensing**.

1.4.6 HOW TO DETERMINE THE HOSTNAME

To retrieve the hostname of a machine, use one of the following methods.

Platform	Method
UNIX	hostname
Windows NT	licadmin or: Go to the Control Panel, open "Network". In the "Identification" tab look for "Computer Name".
Windows XP/2000	licadmin or: Go to the Control Panel, open "System". In the "Computer Name" tab look for "Full computer name".

Table 1-3: Determine the hostname

INSTALLATION

CHAPTER

2

GETTING STARTED



2 | CHAPTER

2.1 INTRODUCTION

With the TASKING TriCore suite you can write, compile, assemble, link and locate applications for the several TriCore cores. The TASKING TriCore suite conforms to Infineon's *TriCore Embedded Applications Binary Interface* (EABI), which defines a set of standards to ensure interoperability between software components.

Embedded Development Environment

The TASKING Embedded Development Environment (EDE) is a Windows application that facilitates working with the tools in the toolchain and also offers project management and an integrated editor.

EDE has three main functions: *Edit / Project management*, *Build* and *Debug*. The figure below shows how these main functionalities relate to each other.

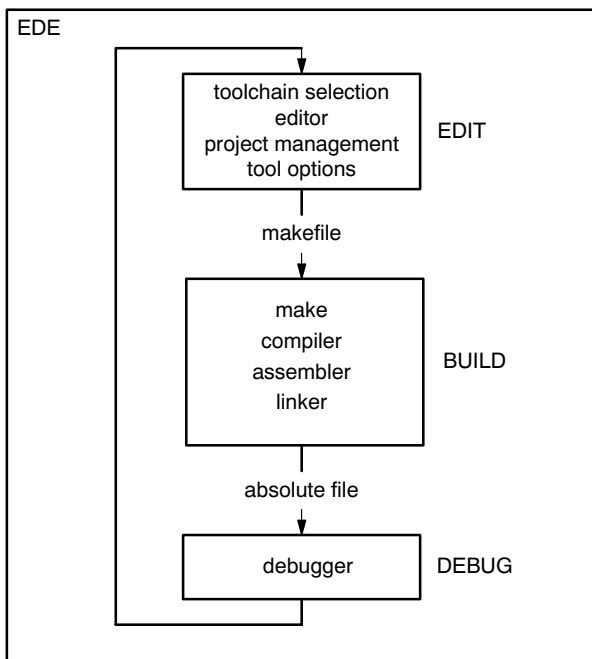

Figure 2-1: EDE development flow

In the **Edit** part you make all your changes:

- create a project space
- create and maintain one or more projects in a project space
- add, create and edit source files in a project
- set the options for each tool in the toolchain
- select another toolchain if you want to create an application for another target than the TriCore.

In the **Build** part you build your files:

- a makefile (created by the Edit part) is used to invoke the needed toolchain components, resulting in an absolute object file.

In the **Debug** part you can debug your project:

- call the TASKING debugger “CrossView Pro” with the generated absolute object file.

This *Getting Started* Chapter guides you step-by-step through the most important features of EDE

The TASKING EDE is an *embedded* environment and differs from a *native* program development.

A *native* program development environment is often used to develop applications for systems where the host system and the target are the same. Therefore, it is possible to run a compiled application directly from the development environment.

In an *embedded* environment, however, a simulator or target hardware is required to run an application. TASKING offers a number of simulators and target hardware debuggers.

Toolchain overview

You can use all tools in the toolchain from the embedded development environment (EDE) and from the command line in a Command Prompt window or a UNIX shell.

The next illustration shows all components of the TriCore toolchain with their input and output files.

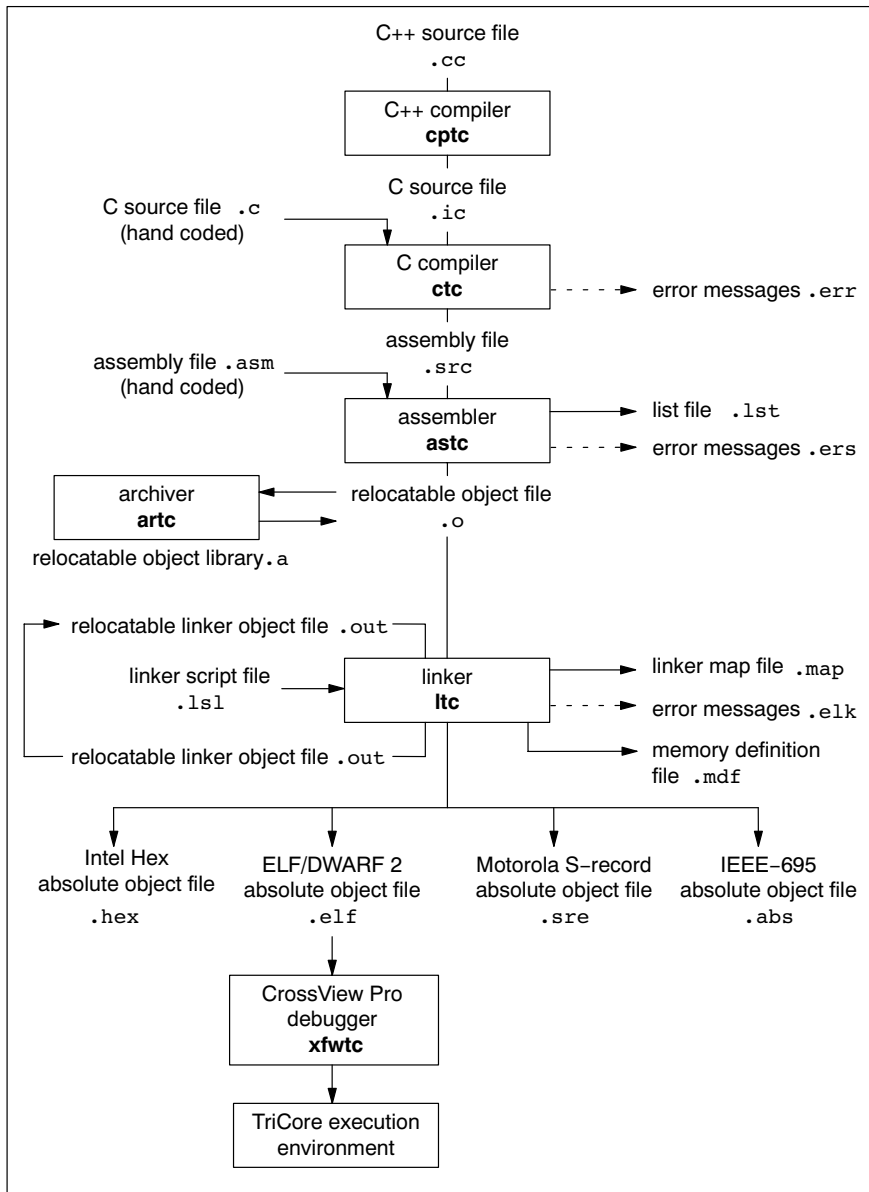

Figure 2-2: TriCore toolchain

The following table lists the file types used by the TriCore toolchain.

Extension	Description
Source files	
.cc	C++ source file, input for the C++ compiler
.c	C source file, input for the C compiler
.asm	Assembler source file, hand coded
.lsl	Linker script file using the Linker Script Language
Generated source files	
.ic	C source file, generated by the C++ compiler, input for the C compiler
.src	Assembler source file, generated by the C compiler, does not contain macros
Object files	
.o	ELF/DWARF relocatable object file, generated by the assembler
.a	Archive with ELF/DWARF object files
.abs	IEEE-695 absolute object file, generated by the locating part of the linker
.out	Relocatable linker output file
.elf	ELF/DWARF absolute object file, generated by the locating part of the linker
.hex	Absolute Intel Hex object file
.sre	Absolute Motorola S-record object file
List files	
.lst	Assembler list file
.map	Linker map file
.mdf	Memory definition file
.mcr	MISRA C report file
Error list files	
.err	Compiler error messages file
.ers	Assembler error messages file
.elk	Linker error messages file

Table 2-1: File extensions

2.2 WORKING WITH PROJECTS IN EDE

EDE is a complete project environment in which you can create and maintain project spaces and projects. EDE gives you direct access to the tools and features you need to create an application from your project.

A *project space* holds a set of projects and must always contain at least one project. Before you can create a project you have to setup a project space. All information of a project space is saved in a *project space file* (**.psp**):

- a list of projects in the project space
- history information

Within a project space you can create *projects*. Projects are bound to a target! You can create, add or edit files in the project which together form your application. All information of a project is saved in a *project file* (**.pjt**):

- the target for which the project is created
- a list of the source files in the project
- the options for the compiler, assembler, linker and debugger
- the default directories for the include files, libraries and executables
- the build options
- history information

When you build your project, EDE handles file dependencies and the exact sequence of operations required to build your application. When you push the **Build** button, EDE generates a makefile, including all dependencies, and builds your application.

Overview of steps to create and build an application

1. Create a project space
2. Add one or more projects to the project space
3. Add files to the project
4. Edit the files
5. Set development tool options
6. Build the application

2.3 START EDE

Start EDE

- Double-click on the EDE shortcut on your desktop.
- OR –

Launch EDE via the program folder created by the installation program.
Select **Start -> Programs -> TASKING toolchain -> EDE**.



Figure 2-3: EDE icon

The EDE screen contains a menu bar, a toolbar with command buttons, one or more windows (default, a window to edit source files, a project window and an output window) and a status bar.

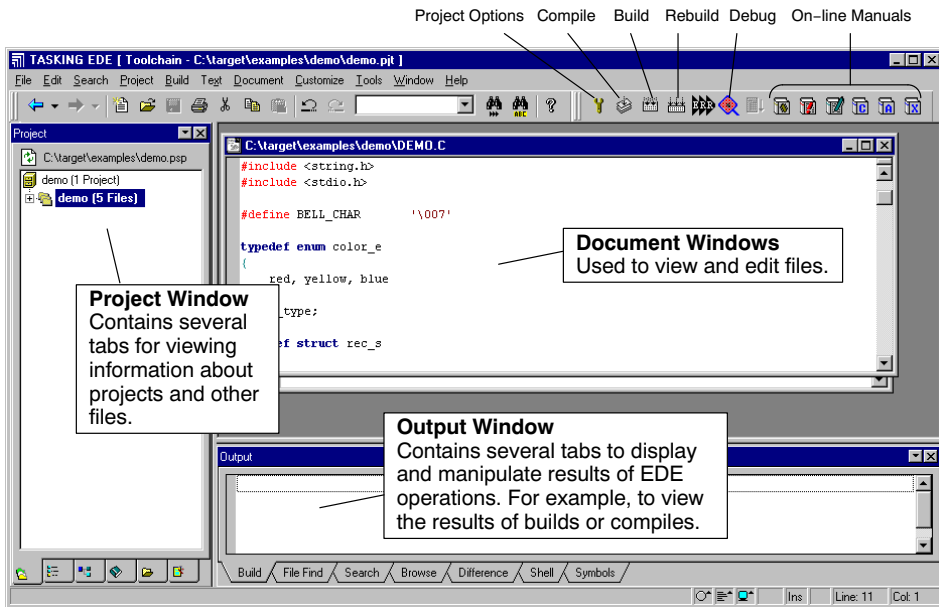

Figure 2-4: EDE desktop

2.4 USING THE SAMPLE PROJECTS

When you start EDE for the first time (see section 2.3, *Start EDE*), EDE opens with a ready defined project space that contains several sample projects. Each project has its own subdirectory in the `examples` directory. Each directory contains a file `readme.txt` with information about the example. The default project is called `demo.pjt` and contains a CrossView Pro debugger example.

Select a sample project

To select a project from the list of projects in a project space:

1. In the Project Window, right-click on the project you want to open.

A menu appears.

2. Select **Set as Current Project**.

The selected project opens.

3. Read the file `readme.txt` for more information about the selected sample project.

Building a sample project

To build the currently active sample project:

- Click on the **Execute 'Make' command** button.



*Once the files have been processed you can inspect the generated messages in the **Build** tab of the **Output** window.*

2.5 CREATE A NEW PROJECT SPACE WITH A PROJECT

Creating a project space is in fact nothing more than creating a project space file (`.psp`) in an existing or new directory.

Create a new project space

1. From the **File** menu, select **New Project Space...**

The Create a New Project Space dialog appears.

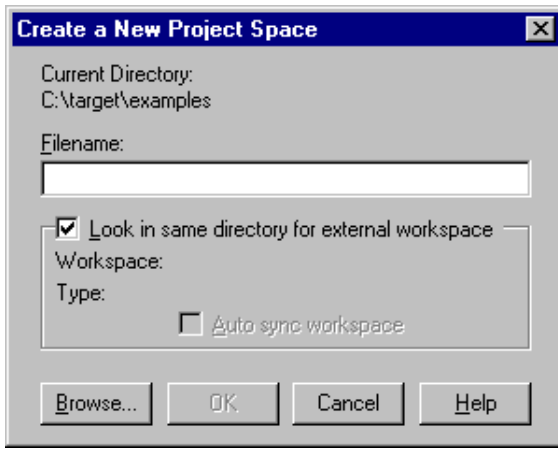

2. In the the **Filename** field, enter a name for your project space (for example **MyProjects**). Click the **Browse** button to select a directory first and enter a filename.
3. Check the directory and filename and click **OK** to create the **.psp** file in the directory shown in the dialog.

*A project space information file with the name **MyProjects.psp** is created and the Project Properties dialog box appears with the project space selected.*

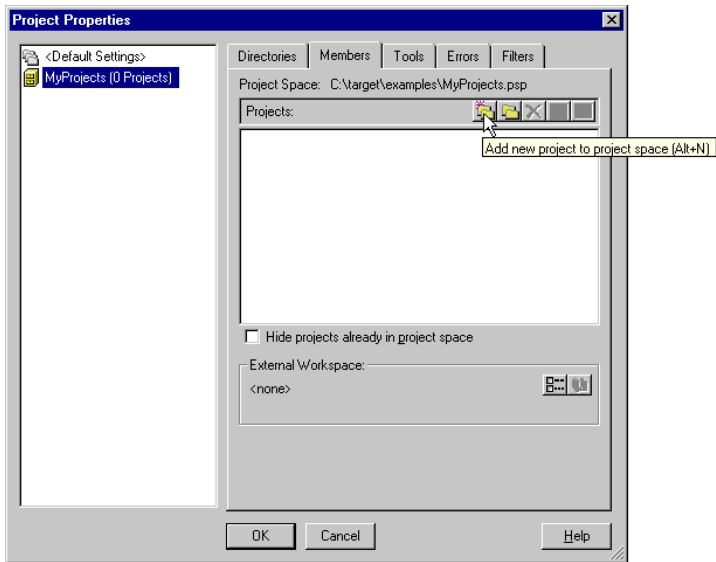

Add a new project to the project space

4. In the Project Properties dialog, click on the **Add new project to project space** button (see previous figure).

The Add New Project to Project Space dialog appears.

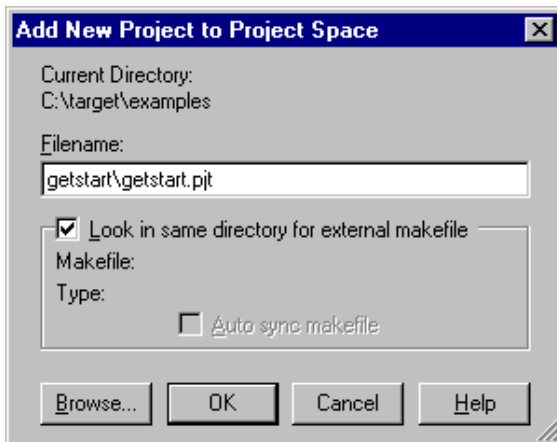

5. Give your project a name, for example `getstart\getstart.pjt` (a directory name to hold your project files is optional) and click **OK**.

A project file with the name `getstart.pjt` is created in the directory `getstart`, which is also created. The Project Properties dialog box appears with the project selected.

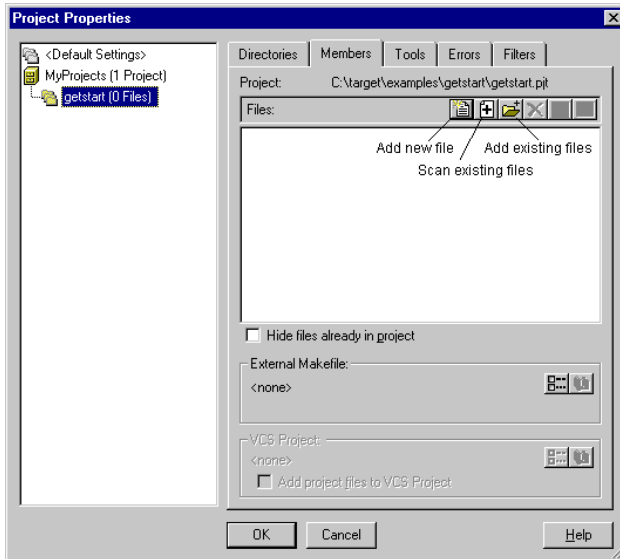

Add new files to the project

Now you can add all the files you want to be part of your project.

6. Click on the **Add new file to project** button.

The Add New File to Project dialog appears.

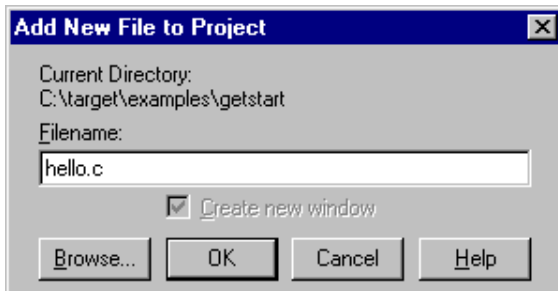

7. Enter a new filename (for example `hello.c`) and click **OK**.

A new empty file is created and added to the project. Repeat steps 6 and 7 if you want to add more files.

8. Click **OK**.

The new project is now open. EDE loads the new file(s) in the editor in separate document windows.

EDE automatically creates a *makefile* for the project (in this case `getstart.mak`). This file contains the rules to build your application. EDE updates the makefile every time you modify your project.

Edit your files

9. As an example, type the following C source in the `hello.c` document window:

```
#include <stdio.h>

void main(void)
{
    printf("Hello World!\n");
}
```

10. Click on the **Save the changed file <Ctrl-S>** button.



EDE saves the file.

2.6 SET OPTIONS FOR THE TOOLS IN THE TOOLCHAIN

The next step in the process of building your application is to select a target processor and specify the options for the different parts of the toolchain, such as the C and/or C++ compiler, assembler, linker and debugger.

Select a target processor

1. From the **Project** menu, select **Project Options...**

The Project Options dialog appears.

2. Expand the **Processor** entry and select **Processor Definition**.

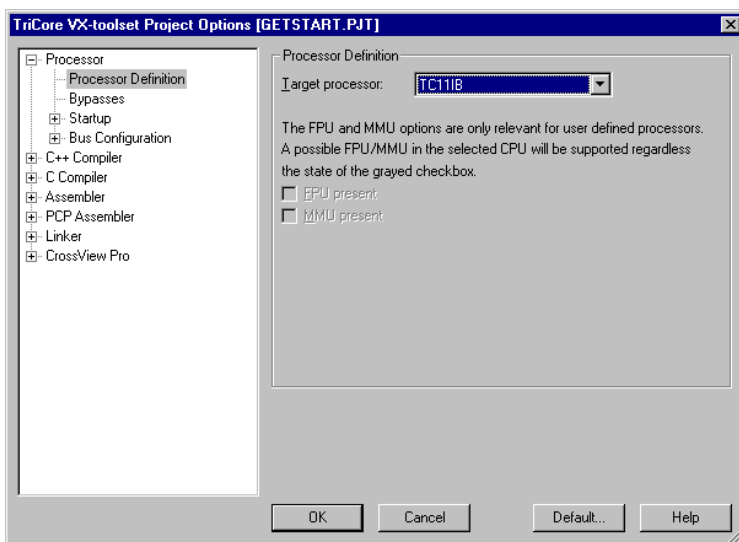

3. In the **Target processor** list select (for example) **TC111B**.
4. Click **OK** to accept the new project settings.

Set tool options

1. From the **Project** menu, select **Project Options...**

*The Project Options dialog appears. Here you can specify options that are valid for the entire project. To overrule the project options for the currently active file instead, from the **Project** menu select **Current File Options...***

- Expand the **C Compiler** entry.

The C Compiler entry contains several pages where you can specify C compiler settings.

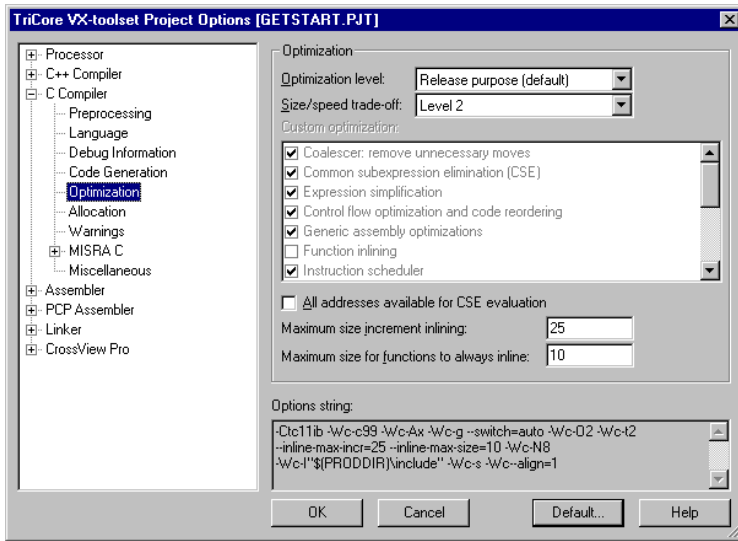

- For each page make your changes. If you have made all changes click **OK**.



The **Cancel** button closes the dialog without saving your changes. With the **Defaults** button you can restore the default project options (for the current page, or all pages in the dialog).

- Make your changes for all other entries (Assembler, Linker, CrossView Pro) of the Project Options dialog in a similar way as described above for the C compiler.



If available, the **Options string** field shows the command line options that correspond to your graphical selections.

2.7 BUILD YOUR APPLICATION

If you have set all options, you can actually compile the file(s). This results in an absolute ELF/DWARF object file which is ready to be debugged.

Build your Application

To build the currently active project:

- Click on the **Execute 'Make' command** button.



The file is compiled, assembled, linked and located. The resulting file is `getstart.elf`.



The build process only builds files that are out-of-date. So, if you click **Make** again in this example nothing is done, because all files are up-to-date.

Viewing the Results of a Build

Once the files have been processed, you can see which commands have been executed (and inspect generated messages) by the build process in the **Build** tab of the **Output** window.

This window is normally open, but if it is closed you can open it by selecting the **Output** menu item in the **Window** menu.

Compiling a Single File

1. Select the window (document) containing the file you want to compile or assemble.
2. Click on the **Execute 'Compile' command** button. The following button is the execute Compile button which is located in the toolbar.



If you selected the file `hello.c`, this results in the compiled and assembled file `hello.o`.

Rebuild your Entire Application

If you want to compile, assemble and link/locate all files of your project from scratch (regardless of their date/time stamp), you can perform a rebuild.

- Click on the **Execute 'Rebuild' command** button. The following button is the execute Rebuild button which is located in the toolbar.



2.8 HOW TO BUILD YOUR APPLICATION ON THE COMMAND LINE

If you are not using EDE, you can build your entire application on the command line. The easiest way is to use the *control program* **cctc**.

1. In a text editor, write the file **hello.c** with the following contents:

```
#include <stdio.h>

void main(void)
{
    printf("Hello World!\n");
}
```

2. Build the file **getstart.elf**:

```
cctc -ogetstart.elf hello.c -v
```

*The control program calls all tools in the toolchain. The **-v** option shows all the individual steps. The resulting file is **getstart.elf**.*

2.9 DEBUG GETSTART.ELF

The application `getstart.elf` is the final result, ready for execution and/or debugging. The debugger uses `getstart.elf` for debugging but needs symbolic debug information for the debugging process. This information must be included in `getstart.elf` and therefore you need to compile and assemble `hello.c` once again.

```
cctc -g -ogetstart.elf hello.c
```

Now you can start the debugger with `getstart.elf` and see how it executes.

Start CrossView Pro

- Click on the **Debug application** button.



CrossView Pro is launched. CrossView Pro will automatically download the file `getstart.elf` for debugging.



See the *CrossView Pro Debugger User's Manual* for more information.

CHAPTER

3

TRICORE C LANGUAGE



3 | CHAPTER

3.1 INTRODUCTION

The TASKING C cross-compiler (**ctc**) fully supports the ISO C standard and adds extra possibilities to program the special functions of the TriCore.

In addition to the standard C language, the compiler supports the following:

- extra data types, like `__fract`, `__laccum` and `__packb`
- intrinsic (built-in) functions that result in TriCore specific assembly instructions
- pragmas to control the compiler from within the C source
- predefined macros
- the possibility to use assembly instructions in the C source
- keywords to specify memory types for data and functions
- attributes to specify alignment and absolute addresses

All non-standard keywords have two leading underscores (`__`).

In this chapter the TriCore specific characteristics of the C language are described, including the above mentioned extensions.

3.2 DATA TYPES

3.2.1 FUNDAMENTAL DATA TYPES

The TriCore architecture defines the following fundamental data types:

- An 8-bit byte
- A 16-bit short
- A 32-bit word
- A 64-bit double word

The next table shows the mapping between these fundamental data types and the C language data types.

Type	Keyword	Size (bit)	Align (bit)	Ranges
Boolean	<code>_Bool</code>	8	8	0 or 1
Character	<code>char</code> <code>signed char</code>	8	8	$-2^7 .. 2^7-1$
	<code>unsigned char</code>	8	8	$0 .. 2^8-1$
Integral	<code>short</code> <code>signed short</code>	16	16	$-2^{15} .. 2^{15}-1$
	<code>unsigned short</code>	16	16	$0 .. 2^{16}-1$
	<code>int</code> <code>signed int</code> <code>long</code> <code>signed long</code>	32	16	$-2^{31} .. 2^{31}-1$
	<code>unsigned int</code> <code>unsigned long</code>	32	16	$0 .. 2^{32}-1$
	<code>enum</code>	8 16 32	8 16	$-2^7 .. 2^7-1$ $-2^{15} .. 2^{15}-1$ $-2^{31} .. 2^{31}-1$
	<code>long long</code> <code>signed long long</code>	64	32	$-2^{63} .. -2^{63}-1$
	<code>unsigned long long</code>	64	32	$0 .. 2^{64}-1$
	Pointer	<code>pointer to data</code> <code>pointer to func</code>	32	32
Floating-Point	<code>float</code>	32	16	$-3.402e^{38} .. -1.175e^{-38}$ $1.175e^{-38} .. 3.402e^{38}$
	<code>double</code> <code>long double</code>	64	32	$-1.797e^{308} .. -2.225e^{-308}$ $2.225e^{-308} .. 1.797e^{308}$

Table 3-1: Data Types

When you use the `enum` type, the compiler will use the smallest sufficient integer type, unless you use compiler option `--integer-enumeration` (always use 32-bit integers for enumeration).



See also the *TriCore Embedded Applications Binary Interface (EABI)*.

3.2.2 FRACTIONAL DATA TYPES

The TASKING TriCore C compiler **ctc** additionally supports the following *fractional* types:

Type	Keyword	Size (bit)	Align (bit)	Ranges
Fract	<code>__sfract</code>	16	16	<code>[-1, 1></code>
	<code>__fract</code>	32	32	<code>[-1, 1></code>
Accum	<code>__laccum</code>	64	64	<code>[-131072,131072></code>

Table 3-2: Fractional Data Types

The `__sfract` type has 1 sign bit + 15 mantissa bits

The `__fract` type has 1 sign bit + 31 mantissa bits

The `__laccum` type has 1 sign bit + 17 integral bits + 46 mantissa bits.



The `_accum` type is only included for compatibility reasons and is mapped to `__laccum`.

The TASKING C compiler **ctc** fully supports fractional data types which allow you to use normal expressions:

```

__fract f, f1, f2; /* Declaration of fractional variables */
f1 = 0.5;          /* Assignment of a fractional constants */
f2 = 0.242;
f = f1 * f2;      /* Multiplication of two fractionals */

```

The TriCore instruction set supports most basic operation on fractional types directly. To obtain more portable code, you can use several intrinsic functions that use fractional types. Fractional values are automatically saturated.



Section 3.5, *Intrinsic Functions* explains intrinsic functions.

Section 1.5.2, *Fractional Arithmetic Support* in Chapter *TriCore C Language* of the *Reference Manual* lists the intrinsic functions.

Promotion rules

For the three fractional types, the promotion rules are similar to the promotion rules for `char`, `short`, `int`, `long` and `long long`. This means that for an operation on two different fractional types, the smaller type is promoted to the larger type before the operation is performed.

When you mix a fractional type with a `float` or `double` type, the fractional number is first promoted to `float` respectively `double`.

When you mix an integer type with the `__laccum` type, the integer is first promoted to `__laccum`.

Because of the limited range of `__sfract` and `__fract`, only a few operations make sense when combining an integer with an `__sfract` or `__fract`. Therefore, the TriCore compiler only supports the following operations for integers combined with fractional types:

left	oper	right	result
fractional	*	integer	fractional
integer	*	fractional	fractional
fractional	/	integer	fractional
fractional	<<	integer	fractional
fractional	>>	integer	fractional
fractional: <code>__sfract</code> , <code>__fract</code>			
integer: <code>char</code> , <code>short</code> , <code>int</code> , <code>long</code> , <code>long long</code>			

Table 3-3: Fractional operations for integers with fractional types

3.2.3 BIT DATA TYPE

The TASKING TriCore C compiler `ctc` additionally supports the *bit* data type:

Type	Keyword	Size (bit)	Align (bit)	Range
Bit	<code>__bit</code>	8	8	0 or 1

Table 3-4: Bit Data Type

The TriCore instruction set supports some operations of the `__bit` type directly.

The following rules apply to `__bit` type variables:

- A `__bit` type variable is always unsigned.
- A `__bit` type variable can be exchanged with all other type-variables. The compiler generates the correct conversion.

A `__bit` type variable is like a boolean. Therefore, if you convert an `int` type variable to a `__bit` type variable, it becomes 1 (true) if the integer is not equal to 0, and 0 (false) if the integer is 0. The next two C source lines have the same effect:

```
bit_variable = int_variable;  
bit_variable = int_variable ? 1 : 0;
```

- Pointer to `__bit` is **not** allowed when it has the `__atbit()` qualifier.
- The `__bit` type is allowed as a structure member.
- A `__bit` type variable is allowed as a parameter of a function.
- A `__bit` type variable is allowed as a return type of a function.
- A `__bit` typed expression is allowed as switch expression.
- The `sizeof` of a `__bit` type is 1.
- Global or static `__bit` type variable can be initialized.
- A `__bit` type variable can be declared absolute using the `__atbit` attribute. See section 3.3.2 *Declare a Data Object at an Absolute Address: `__at()` and `__atbit()`* for more details.
- A `__bit` type variable can be declared volatile.

Promotion Rules

For the `__bit` type, the promotion rules are similar to the promotion rules for `char`, `short`, `int`, `long` and `long long`.

3.2.4 PACKED DATA TYPES

The TASKING TriCore C compiler **ctc** additionally supports the following *packed* types:

Type	Keyword	Size (bit)	Align (bit)	Ranges
Packed	<code>__packb</code> signed <code>__packb</code>	32	16	4x: $-2^7 .. 2^7-1$
	unsigned <code>__packb</code>	32	16	4x: $0 .. 2^8-1$
	<code>__packhw</code> signed <code>__packhw</code>	32	16	2x: $-2^{15} .. 2^{15}-1$
	unsigned <code>__packhw</code>	32	16	2x: $0 .. 2^{16}-1$

Table 3-5: Fractional Data Types

A `__packb` value consists of four signed or unsigned `char` values.

A `__packhw` value consists of two signed or unsigned `short` values.

The TriCore instruction set supports a number of arithmetic operations on packed data types directly. For example, the following function:

```
__packb add4 ( __packb a, __packb b )
{
    return a + b;
}
```

results into the following assembly code:

```
add4:
    add.b    d2,d4,d5
    ret16
```



Section 3.5, *Intrinsic Functions* explains intrinsic functions.

Section 1.5.3, *Packed Data Type Support* in Chapter *TriCore C Language* of the *Reference Manual* lists the intrinsic functions.

Halfword Packed Unions and Structures

To minimize space consumed by alignment padding with unions and structures, elements follow the minimum alignment requirements imposed by the architecture. The TriCore architecture supports access to 32-bit integer variables on halfword boundaries.

Because only doubles, circular buffers, `__laccum` or pointers require the full word access, structures that do not contain members of these types are automatically halfword (2-bytes) packed.

Structures and unions that are divisible by 64-bit or contain members that are divisible by 64-bit, are word packed to allow efficient access through `LD.D` and `ST.D` instructions. These load and store operations require word aligned structures that are divisible by 64-bit. If necessary, 64-bit divisible structure elements are aligned or padded to make the structure 64-bit accessible.

With **`#pragma pack 2`** you can disable the `LD.D/ST.D` structure and union copy optimization to ensure halfword structure and union packing when possible. This "limited" halfword packing only supports structures and unions that do not contain double, circular buffer, `__laccum` or pointer type members and that are not qualified with **`#pragma align`** to get an alignment larger than 2-byte. With **`#pragma pack 0`** you turn off halfword packing again.

```
#pragma pack 2
typedef struct {
    unsigned char  uc1;
    unsigned char  uc2;
    unsigned short us1;
    unsigned short us2;
    unsigned short us3;
} packed_struct;
#pragma pack 0
```

When you place a **`#pragma pack 0`** before a structure or union, its alignment will not be changed:

```
#pragma pack 0
packed_struct pstruct;
```

The alignment of data sections and stack can also affect the alignment of the base address of a halfword packed structure. A halfword packed structure can be aligned on a halfword boundary or larger alignment. When located on the stack or at the beginning of a section, the alignment becomes a word, because of the minimum required alignment of data sections and stack objects. A stack or data section can contain any type of object. To avoid wrong word alignment of objects in the section, the section base is also word aligned.

3.3 MEMORY QUALIFIERS

You can use static memory qualifiers to allocate static objects in a particular part of the addressing space of the processor.

In addition, you can place variables at absolute addresses with the keyword `__at()`. If you declare an integer at an absolute address, you can declare a single bit of that variable as bit variable with the keyword `__atbit()`.

3.3.1 DECLARE A DATA OBJECT IN A SPECIAL PART OF MEMORY

With a memory qualifier you can declare a variable in a specific part of the addressing space. You can use the following memory qualifiers:

- `__near`** The declared data object will be located in the first 16 kB of a 256 MB block. These parts of memory are directly addressable with the absolute addressing mode (see section 4.4.1, *Operands and Addressing Modes*, in Chapter *TriCore Assembly Language*).
- `__far`** The data object can be located anywhere in the indirect addressable memory region.

If you do not specify `__near` or `__far`, the compiler chooses where to place the declared object. With the compiler option `-N` (maximum size in bytes for data elements that are default located in `__near` sections) you can specify the size of data objects which the compiler then by default places in near memory.

- `__a0`** The data object is located in a section that is addressable with a sign-extended 16-bit offset from address register **A0**.
- `__a1`** The data object is located in a section that is addressable with a sign-extended 16-bit offset from address register **A1**.
- `__a8`** The data object is located in a section that is addressable with a sign-extended 16-bit offset from address register **A8**.
- `__a9`** The data object is located in a section that is addressable with a sign-extended 16-bit offset from address register **A9**.

Address registers **A0**, **A1**, **A8**, and **A9** are designated as system global registers. They are not part of either context partition and are not saved/restored across calls. They can be protected against write access by user applications.

By convention, **A0** and **A1** are reserved for compiler use, while **A8** and **A9** are reserved for OS or application use. **A0** is used as a base pointer to the *small* data section, where global data elements can be accessed using base + offset addressing. **A0** is initialized by the execution environment.

A1 is used as a base pointer to the *literal data section*. The literal data section is a read-only data section intended for holding address constants and program literal values. Like **A0**, it is initialized by the execution environment.

As noted, **A8** and **A9** are reserved for OS use, or for application use in cases where the application and OS are tightly coupled.

All these memory qualifiers (`__near`, `__far`, `__a0`, `__a1`, `__a8` and `__a9`) are related to the object being defined, they influence *where* the object will be located in memory. They are not part of the type of the object defined. Therefore, you cannot use these qualifiers in typedefs, type casts or for members of a struct or union.

Examples:

To declare a fast accessible integer in directly addressable memory:

```
int __near Var_in_near;
```

To allocate a pointer in far memory (the compiler will not use absolute addressing mode):

```
__far int *Ptr_in_far;
```

To declare and initialize a string in **A0** memory:

```
char __a0 string[] = "TriCore";
```

If you use the `__near` memory qualifier, the compiler generates faster access code for those (frequently used) variables. Pointers are always 32-bit.

Functions are by default allocated in ROM. In this case you can omit the a memory qualifier. You cannot use memory qualifiers for function return values.

Some examples of using memory qualifiers:

```
int __near *p;    /* pointer to int in __near memory
                  (pointer has 32-bit size)    */
int __far *g;    /* pointer to int in __far memory
                  (pointer has 32-bit size)    */

g = p;          /* the compiler issues a warning */
```

You cannot use memory qualifiers in structure declarations:

```
struct S {
    __near int i; /* put an integer in near
                  memory: Incorrect !      */
    __far int *p; /* put an integer pointer in
                  far memory: Incorrect !  */
}
```

If a library function declares a variable in near memory and you try to redeclare the variable in far memory, the linker issues an error:

```
extern int __near foo; /* extern int in near memory*/
int __far foo;        /* int in far memory      */
```

The usage of the variables is always without a storage specifier:

```
char __near example;
example = 2;
```

The generated assembly would be:

```
mov16 d15,2
st.b  example,d15
```

All allocations with the same storage specifiers are collected in units called 'sections'. The section with the `__near` attribute will be located within the first 16 kB of of each 256 MB block.



With the linker it is possible to control the location of sections manually. See Chapter 7 Linker.

3.3.2 DECLARE A DATA OBJECT AT AN ABSOLUTE ADDRESS: `__at()` AND `__atbit()`

Just like you can declare a variable in a specific *part* of memory, you can also place an object at an *absolute address* in memory. This may be useful to interface with other programs using fixed memory schemes, or to access special function registers.

With the attribute `__at()` you can specify an absolute address.

Examples

```
int myvar __at(0x100);
```

The variable `myvar` is placed at address `0x100`.

```
unsigned char Display[80*24] __at( 0x2000 )
```

The array `Display` is placed at address `0x2000`. In the generated assembly, an absolute section is created. On this position space is reserved for the variable `Display`.

Restrictions

Take note of the following restrictions if you place a variable at an absolute address:

- You can place only global variables at absolute addresses. Parameters of functions, or automatic variables within functions cannot be placed at absolute addresses.
- When declared `extern`, the variable is not allocated by the compiler. When the same variable is allocated within another module but on a different address, the compiler, assembler or linker will not notice, because an assembler external object cannot specify an absolute address.
- When the variable is declared `static`, no public symbol will be generated (normal C behavior).
- You cannot place functions at absolute addresses.
- Absolute variables cannot overlap each other. If you declare two absolute variables at the same address, the assembler and / or linker issues an error. The compiler does not check this.
- When you declare the same absolute variable within two modules, this produces conflicts during link time (except when one of the modules declares the variable 'extern').

Declaring a bit variable with `__atbit()`

If you have defined a 32-bits base variable (`int`, `long`) you can declare a single bit of that variable as a bit variable with the keyword `__atbit()`. The syntax is:

```
__atbit( name, offset )
```

name is the name of an integer variable in which the bit is located. *offset* (range 0-31) is the bit-offset within the variable.

If you have defined an absolute integer variable with the keyword `__at()`, you can declare a single bit of that variable as an absolute bit variable with `__atbit()`.

Example

```
int          bw  __at(0x100);
__bit       myb  __atbit( bw, 3 );
```

Note that the keyword `__bit` is used to declare the variable `myb` as a bit, and that the keyword `__atbit()` is used to declare that variable at an absolute offset in variable `bw`.



See also section 3.2.3, *Bit Data Type*.

Restrictions

- You can only use the `__atbit()` qualifier on variables of type `__bit`.
- When a variable is `__atbit()` qualified it represents an alias of a bit in another variable. Therefore, it cannot be initialized.
- You can only use the `__atbit()` qualifier on variables which have either a global scope or file scope.

3.4 DATA TYPE QUALIFIERS

3.4.1 CIRCULAR BUFFERS: `__circ`

The TriCore core has support for implementing specific DSP tasks, such as finite impulse response (FIR) and infinite impulse response (IIR) filters and fast Fourier transforms (FFTs). For the FIR and IIR filters the TriCore architecture supports the circular addressing mode and for the FFT the bit-reverse addressing mode. The TriCore C compiler supports *circular buffers* for these DSP tasks. This way, the TriCore C compiler makes hardware features available at C source level instead of at assembly level only.

A *circular buffer* is a linear (one dimensional) array that you can access by moving a pointer through the data. The pointer can jump from the last location in the array to the first, or vice-versa (the pointer wraps-around). This way the buffer appears to be continuous. The TriCore C compiler supports the `__circ` keyword (circular addressing mode) for this type of buffer.

Example: `__circ`

```
__fract __circ circbuffer[10];  
__fract __circ *ptr_to_circbuffer = circbuffer;
```

Here, `circbuffer` is declared as a circular buffer. The compiler aligns the base address of the buffer on the access width (in this example an `int`, so 4 bytes). The compiler keeps the buffer size and uses it to control pointer arithmetic of pointers that are assigned to the buffer later.

You can perform operations on circular pointers with the usual C pointer arithmetic with the difference that the pointer will wrap. When you access the circular buffer with a circular pointer, it wraps at the buffer limits. Circular pointer variables are 64 bits in size.

Example:

```
while( *Pptr_to_circbuf++ );
```

Indexing in the circular buffer, using an integer index, is treated equally to indexing in a non-circular array.

Example:

```
int i = circbuf[3];
```

The index is not calculated modulo; indexing outside the array boundaries yields undefined results.

If you want to initialize a circular pointer with a dynamically allocated buffer at run-time, you should use the intrinsic function `__initcirc()`:

```
#define N 100
unsigned short s = sizeof(__fract);
__fract *ptr_to_circbuf = calloc( N, s );
circbuf = __initcirc( ptr_to_circbuf, N * s, 0 * s );
```

3.4.2 DECLARE AN SFR BIT FIELD: `__sfrbit16` AND `__sfrbit32`

With the data type qualifiers `__sfrbit16` and `__sfrbit32` you can declare bit fields in special function registers.

According to the *TriCore Embedded Applications Binary Interface*, 'normal' bit fields are accessed as `char`, `short` or `int`. Thus:

- fields with a width of 8-bits or less impose only byte alignments
- fields with a width from 9 to 16 bits impose halfword alignment
- fields with a width from 17 to 32 bits impose word alignment

If you declare bit fields in special function registers, this behavior is not always desired: some special function registers require 16-bit or 32-bit access. To force 16-bit or 32-bit access, you can use the data type qualifiers `__sfrbit16` and `__sfrbit32`.



For each supported target, a special function register file (`regcpu_name.sfr`) is delivered with the TriCore toolchain. In normal circumstances you should not need to declare SFR bit fields.

Example

The next example is part of an SFR file and illustrates the declaration of a special function register using the data type qualifier `__sfrbit32`:

```

typedef volatile union
{
    struct
    {
        unsigned __sfrbit32 SRPN : 1; /* BCU Service Priority
                                     Number          */
        unsigned int : 2;
        unsigned __sfrbit32 TOS : 2; /* BCU Type-of-Service
                                     Control          */
        unsigned __sfrbit32 SRE : 1; /* BCU Service Request
                                     Enable Control    */
        unsigned __sfrbit32 SRR : 1; /* BCU SerService Request
                                     Flag              */
        unsigned __sfrbit32 CLRR : 1; /* BCU Request Clear Bit */
        unsigned __sfrbit32 SETR : 1; /* BCU Request Set Bit  */
        unsigned int : 16;
    } B;

    int I;
} BCU_SRC_type;

#define BCU_SRC (*(BCU_SRC_type*)(0xF00002FC))
/* BCU Service Request Node          */

```

You can now access the register and bit fields as follows:

```

#include <regtc10gp.sfr>

BCU_SRC.I |= 0xb32a; /* access BCU Service Request
                    Control register as a whole      */

BCU_SRC.B.SRE = 0x1; /* access SRE bit field of BCU
                    Service Request Control register */

```

Restrictions

You can use the `__sfrbit32` and `__sfrbit16` data type qualifiers only for `int` types. The compiler issues an error if you use for example `__sfrbit32 char x : 8;`

When you use the `__sfrbit32` and `__sfrbit16` data type qualifiers for other types than a bit field, the compiler ignores this without a warning. For example, `__sfrbit32 int global;` is equal to `int global;`.

Structures or unions that contain a member qualified with `__sfrbit16`, are zero padded to complete a halfword if necessary. The structure or union will be halfword aligned.

Structures or unions that contain a member qualified with `__sfrbit32`, are zero padded to complete a full word if necessary. The structure or union will be word aligned.

3.5 INTRINSIC FUNCTIONS

Some specific TriCore assembly instructions have no equivalence in C. *Intrinsic functions* give the possibility to use these instructions. Intrinsic functions are predefined functions that are recognized by the compiler. The compiler then generates the most efficient assembly code for these functions.

The compiler always inlines the corresponding assembly instructions in the assembly source rather than calling the function. This avoids unnecessary parameter passing and register saving instructions which are normally necessary when a function is called.

Intrinsic functions produce very efficient assembly code. Though it is possible to inline assembly code by hand, registers are used even more efficient by intrinsic functions. At the same time your C source remains very readable.

You can use intrinsic functions in C as if they were ordinary C (library) functions. All intrinsics begin with a double underscore character. The following example illustrates the use of an intrinsic function and its resulting assembly code.

```
x = __min( 4,5 );
```

The resulting assembly code is inlined rather than being called:

```
movl6    d2,#4
min      d2,d2,#5
```

The intrinsics cover the following subjects:

- Minimum and maximum of (short) integers
- Fractional data type support
- Packed data type support
- Interrupt handling
- Insert single assembly instruction
- Register handling
- Insert / extract bitfields and bits
- Miscellaneous



For extended information about all available intrinsic functions, refer to section 1.5, *Intrinsic Functions*, in Chapter *TriCore C Language* of the *Reference Manual*.

3.6 USING ASSEMBLY IN THE C SOURCE: `__asm()`

With the `__asm()` keyword you can use assembly instructions in the C source and pass C variables as operands to the assembly code. Be aware that C modules that contain assembly are not portable and harder to compile in other environments.

The compiler does not interpret assembly blocks but passes the assembly code to the assembly source file. Possible errors can only be detected by the assembler.

General syntax of the `__asm` keyword

```
__asm( "instruction_template"
      [ : output_param_list
      [ : input_param_list
      [ : register_save_list]] ] );
```

<i>instruction_template</i>	Assembly instructions that may contain parameters from the input list or output list in the form: <code>%parm_nr</code>
<code>%parm_nr[.regnum]</code>	Parameter number in the range 0 .. 9. With the optional <i>.regnum</i> you can access an individual register from a register pair or register quad. For example, with register pair <code>d0/d1</code> , <code>.0</code> selects register <code>d0</code> .
<i>output_param_list</i>	<code>[["&constraint_char"(C_expression),...]</code>
<i>input_param_list</i>	<code>[["constraint_char"(C_expression),...]</code>
&	Says that an output operand is written to before the inputs are read, so this output must not be the same register as any input.
<i>constraint_char</i>	Constraint character: the type of register to be used for the <i>C_expression</i> . (see table 3-6)
<i>C_expression</i>	Any C expression. For output parameters it must be an <i>lvalue</i> , that is, something that is legal to have on the left side of an assignment.
<i>register_save_list</i>	<code>[["register_name"],...]</code>
<i>register_name</i>	Name of the register you want to reserve.

Typical example: multiplying two C variables using assembly

```
int a,b,result;

void main( void )
{
    __asm("mul\t%0,%1,%2" : "=d"(result) : "d"(a), "d"(b) );
}
```

generated code:

```
ld.w    d15,a
ld.w    d0,b
mul     d15,d15,d0
st.w    result,d15
```

%0 corresponds to the first C variable, %1 corresponds to the second and so on. The escape sequence `\t` generates a tab.

Specifying registers for C variables

With a *constraint character* you specify the register *type* for a parameter. In the example above, the `d` is used to force the use of data registers for the parameters `a`, `b` and `result`.

You can reserve the registers that are used in the assembly instructions, either in the parameter lists or in the reserved register list (*register_save_list*). The compiler takes account of these lists, so no unnecessary register saves and restores are placed around the inline assembly instructions.

Constraint character	Type	Operand	Remark
a	Address register	a0 .. a15	
d	Data register	d0 .. d15	
e	Data register pair	e0,e2,...,e14	e0 = pair d0/d1, e2 = d2/d3, ...
m	Memory	<i>variable</i>	Stack or memory operand
<i>number</i>	Type of operand it is associated with	same as % <i>number</i>	Indicates that % <i>number</i> and <i>number</i> are the same register.

Table 3-6: Available input/output operand constraints

Loops and conditional jumps

The compiler does not detect loops with multiple `__asm` statements or (conditional) jumps across `__asm` statements and will generate incorrect code for the registers involved.

If you want to create a loop with `__asm`, the whole loop must be contained in a single `__asm` statement. The same counts for (conditional) jumps. As a rule of thumb, all references to a label in an `__asm` statement must be in that same statement.

Example 1: no input or output

A simple example without input or output parameters. You can just output any assembly instruction:

```
__asm( "nop" );
```

Generated code:

```
nop
```

Example 2: using output parameters

Assign the result of inline assembly to a variable. With the constraint `d` a data register is chosen for the parameter; the compiler decides which data register it uses. The `%0` in the instruction template is replaced with the name of this data register. Finally, the compiler generates code to assign the result to the output variable.

```
int result;

void main( void )
{
    __asm( "mov %0,#0xFF" : "=d"(result));
}
```

Generated assembly code:

```
mov    d15,#0xFF
st.w   result,d15
```

Example 3: using input and output parameters

Multiply two C variables and assign the result to a third C variable. Data type registers are necessary for the input and output parameters (constraint `d`, `%0` for `result`, `%1` for `a` and `%2` for `b` in the instruction template). The compiler generates code to move the input expressions into the input registers and to assign the result to the output variable.

```
int a, b, result;

void multiply( void )
{
    __asm( "mul %0, %1, %2": "=d"(result): "d"(a), "d"(b) );
}

void main(void)
{
    multiply();
}
```

Generated assembly code:

```
multiply:
    ld.w    d15,a
    ld.w    d0,b
    mul     d15, d15, d0
    st.w    result,d15

main:
    j      multiply
```

Example 4: reserve registers

If you use registers in the `__asm` statement, reserve them. Same as *Example 3*, but now register `d0` is a reserved register. You can do this by adding a reserved register list (`: "d0"`) (sometimes referred to as 'clobber list'). As you can see in the generated assembly code, register `d0` is not used (the first register used is `d1`).

```
int a, b, result;

void multiply( void )
{
    __asm( "mul %0, %1, %2": "=d"(result): "d"(a), "d"(b) : "d0" );
}
```

Generated assembly code:

```
ld.w    d15,a
ld.w    d1,b
mul     d15, d15, d1
st.w    result,d15
```

Example 5: input and output are the same

If the input and output must be the same you must use a number constraint. The following example inverts the value of the input variable `ivar` and returns this value to `ovar`. Since the assembly instruction `not` uses only one register, the return value has to go in the same place as the input value. To indicate that `ivar` uses the same register as `ovar`, the constraint `'0'` is used which indicates that `ivar` also corresponds with `%0`.

```
int ovar;

void invert(int ivar)
{
    __asm ("not %0": "=d"(ovar): "0"(ivar) );
}

void main(void)
{
    invert(255);
}
```

Generated assembly code:

```
invert:
    not    d4
    st.w  ovar,d4

main:
    mov   d4,#255
    j     invert
```

Example 6: writing your own intrinsic function

Because you can use any assembly instruction with the `__asm` keyword, you can use the `__asm` keyword to create your own intrinsic functions. The essence of an intrinsic function is that it is inlined.

First write a function with assembly in the body using the keyword `__asm`. We use the multiply routine from *Example 3*.

Next make sure that the function is inlined rather than being called. You can do this with the function qualifier `inline`. This qualifier is discussed in more detail in section 3.9.1, *Inlining Functions*.

```

int a, b, result;

inline void __my_mul( void )
{
    __asm( "mul %0, %1, %2": "=d"(result): "d"(a), "d"(b) );
}

void main(void)
{
    // call to function __my_mul
    __my_mul();
}

```

Generated assembly code:

```

main:
    ; __my_mul code is inlined here
    ld.w  d15,a
    ld.w  d0,b
    mul  d15, d15, d0
    st.w  result,d15

```

As you can see, the generated assembly code for the function `__my_mul` is inlined rather than called.

Example 7: accessing individual registers in a register pair

You can access the individual registers in a register pair by adding a '.' after the operand specifier in the assembly part, followed by the index in the register pair.

```

int f1, f2;

void foo(double d)
{
    __asm ("ld.w %0, %2.0\n"
          "\tld.w %1, %2.1": "=&d"(f1), "=d"(f2): "e"(d) );
}

```

The first `ld.w` instruction uses index #0 of argument 2 (which is a double placed in a DxDx register) and the second `ld.w` instruction uses index #1. The input operand is located in register pair d4/d5. The assembly output becomes:

```

ld.w  d15, d4
ld.w  d0, e4,1 ; note that e4,1 corresponds to d5
st.w  f1,d15
st.w  f2,d0
retl6

```

If the index is not a valid index (for example, the register is not a register pair, or the argument has not a register constraint), the '.' is passed into the assembly output. This way you can still use the '.' in assembly instructions.

3.7 CONTROLLING THE COMPILER: PRAGMAS

Pragmas are keywords in the C source that control the behavior of the compiler. Pragmas sometimes overrule compiler options and keywords. In general pragmas give directions to the code generator of the compiler.

For example, you can set a compiler option to specify which optimizations the compiler should perform. With the `#pragma optimize flags` you can set an optimization level for a specific part of the C source. This overrules the general optimization level that is set in the compiler options dialog (command line option `-O`).

Some pragmas have an equivalent command line option. This is useful if you want to overrule certain keywords in the C source without the need to change the C source itself.



See section 5.1, *Compiler Options*, in Chapter 5, *Tool Options*, of the *Reference Manual*.

The compiler recognizes the following pragmas, other pragmas are ignored.

Pragma name	Description
<code>alias symbol=defined-symbol</code>	Defines an alias for a symbol
<code>align {n restore}</code>	Specifies object alignment. See compiler option <code>--align</code> in section 5.1, <i>Compiler Options</i> in Chapter <i>Tool Options</i> of the <i>Reference Manual</i> .
<code>clear</code> <code>noclear</code>	Specifies 'clearing' of non-initialized static/public variables
<code>CPU_functional_problem</code> <code>TC112_functional_problem</code> <code>TC113_functional_problem</code>	Use software work arounds for the specified functional problem. See compiler option <code>--silicon</code> in section 5.1, <i>Compiler Options</i> in Chapter <i>Tool Options</i> of the <i>Reference Manual</i> .

Pragma name	Description
<code>default_a0_size value</code>	Threshold for ' __a0' allocation
<code>default_a1_size value</code>	Threshold for ' __a1' allocation
<code>default_near_size value</code>	Threshold for ' __near' allocation
<code>extension isuffix</code>	Enables the language extension to specify imaginary floating-point constants by adding an 'i' to the constant
<code>extern symbol</code>	Forces an external reference
<code>for_constant_data_use_memory</code> <code>for_extern_data_use_memory</code> <code>for_initialized_data_use_memory</code> <code>for_uninitialized_data_use_memory</code>	Specify a memory for the type of data mentioned in the pragma. You can specify near, far, a0, a8, a9 (or a1 only for constant data)
<code>indirect</code>	Generates code for indirect function calling. See compiler option --indirect in section 5.1, <i>Compiler Options</i> in Chapter <i>Tool Options</i> of the <i>Reference Manual</i> .
<code>indirect-runtime</code>	Generates code for indirect function calling to all runtime functions. See compiler option --indirect-runtime in section 5.1, <i>Compiler Options</i> in Chapter <i>Tool Options</i> of the <i>Reference Manual</i> .
<code>inline</code> <code>noinline</code> <code>smartinline</code>	Specifies function inlining. See section 3.9.1, <i>Inlining Functions</i> .
<code>macro</code> <code>nomacro</code>	Turns macro expansion on (default) or off.
<code>message "string" ...</code>	Emits a message to standard output
<code>object_comment "string"</code>	Generates a .comment section with string in the .src file which then appears in the object file.
<code>optimize flags</code> <code>endoptimize</code>	Controls compiler optimizations. See section 5.3, <i>Compiler Optimizations</i> in Chapter <i>Using the Compiler</i>
<code>pack {2 0}</code>	Specifies packing of structures. See section 3.2.4, <i>Packed Data Types</i> .

Pragma name	Description
<pre>section code_init section const_init section vector_init section data_overlay</pre>	<p>At startup copies corresponding sections to RAM for initialization</p> <p>Allow overlaying data sections</p>
<pre>section type[="name" section all</pre>	<p>Changes section names. See section 3.10, <i>Compiler Generated Sections</i> and compiler option -R in section 5.1, <i>Compiler Options</i> in Chapter <i>Tool Options</i> of the <i>Reference Manual</i></p>
<pre>source nosource</pre>	<p>Specifies which C source lines must be shown in assembly output. See compiler option -s in section 5.1, <i>Compiler Options</i> in Chapter <i>Tool Options</i> of the <i>Reference Manual</i>.</p>
<pre>switch {auto jumptab linear lookup restore}</pre>	<p>Specifies switch statement. See section 3.11, <i>Switch Statement</i></p>
<pre>tradeoff level</pre>	<p>Specify tradeoff between speed (0) and size (4). See compiler option -t in section 5.1, <i>Compiler Options</i> in Chapter <i>Tool Options</i> of the <i>Reference Manual</i>.</p>
<pre>warning [number,...]</pre>	<p>Disables warning messages. See compiler option -w in section 5.1, <i>Compiler Options</i> in Chapter <i>Tool Options</i> of the <i>Reference Manual</i>.</p>
<pre>weak symbol</pre>	<p>Marks a symbol as 'weak'</p>

Table 3-7: Pragmas

3.8 PREDEFINED MACROS

In addition to the predefined macros required by the ISO C standard, the TASKING TriCore C compiler supports the predefined macros as defined in Table 3-8. The macros are useful to create conditional C code.

Macro	Description
<code>__DOUBLE_FP__</code>	Defined when you do not use compiler option <code>-F</code> (Treat double as float)
<code>__SINGLE_FP__</code>	Defined when you use compiler option <code>-F</code> (Treat double as float)
<code>__FPU__</code>	Defined when you use compiler option <code>--fpu-present</code> (Use hardware floating-point instructions)
<code>__CTC__</code>	Identifies the compiler. You can use this symbol to flag parts of the source which must be recognized by the ctc compiler only. It expands to the version number of the compiler.
<code>__TASKING__</code>	Identifies the compiler as the TASKING TriCore compiler. It expands to 1.
<code>__DSPC__</code>	Indicates conformation to the DSP-C standard. It expands to 1.
<code>__DSPC_VERSION__</code>	Expands to the decimal constant 200001L.
<code>__VERSION__</code>	Identifies the version number of the compiler. For example, if you use version 2.1r1 of the compiler, <code>__VERSION__</code> expands to 2001 (dot and revision number are omitted, minor version number in 3 digits).
<code>__REVISION__</code>	Identifies the revision number of the compiler. For example, if you use version 2.1r1 of the compiler, <code>__REVISION__</code> expands to 1.
<code>__BUILD__</code>	Identifies the build number of the compiler, composed of decimal digits for the build number, three digits for the major branch number and three digits for the minor branch number. For example, if you use build 1.22.1 of the compiler, <code>__BUILD__</code> expands to 1022001. If there is no branch number, the branch digits expand to zero. For example, build 127 results in 127000000.

Table 3-8: Predefined macros

3.9 FUNCTIONS

3.9.1 INLINING FUNCTIONS: INLINE

You can use the `inline` keyword to tell the compiler to inline the function body instead of calling the function. Use the `__noinline` keyword to tell the compiler *not* to inline the function body.

You must define inline functions in the same source module as in which you call the function, because the compiler only inlines a function in the module that contains the function definition. When you need to call the inline function from several source modules, you must include the definition of the inline function in each module (for example using a header file).

The compiler inserts the function body at the place the function is called. If the function is not called at all, the compiler does not generate code for it.

Example: inline

```
int w,x,y,z;

inline int add( int a, int b )
{
    int i = 4;
    return( a + b );
}

void main( void )
{
    w = add( 1, 2 );
    z = add( x, y );
}
```

The function `add()` is defined before it is called. The compiler inserts (optimized) code for both calls to the `add()` function. The generated assembly is:

```

main:
    mov16    d15,#3
    st.w     w,d15

    ld.w     d15,x
    ld.w     d0,y
    add16    d0,d15
    st.w     z,d0

```

Example: #pragma inline / #pragma noline

Instead of the `inline` qualifier, you can also use `#pragma inline` and `#pragma noline` to inline a function body:

```

int  w,x,y,z;

#pragma inline
int add( int a, int b )
{
    int i=4;
    return( a + b );
}
#pragma noline

void main( void )
{
    w = add( 1, 2 );
    z = add( x, y );
}

```

If a function has an `inline/__noline` function qualifier, then this qualifier will overrule the current pragma setting.

#pragma smartinline

By default, small functions that are not too often called, are inlined. This reduces execution time at the cost of code size (compiler option **-Oi**).

With the `#pragma noline / #pragma smartinline` you can temporarily disable this optimization.

With the compiler options **--inline-max-incr** and **--inline-max-size** you have more control over the function inlining process of the compiler.



See for more information of these options, section *Compiler Options* in Chapter *Tool Options* of the *TriCore Reference Manual*.

Combining inline with __asm to create intrinsic functions

With the keyword `__asm` it is possible to use assembly instructions in the body of an inline function. Because the compiler inserts the (assembly) body at the place the function is called, you can create your own intrinsic function.



See section 3.6, *Using Assembly in the C Source*, for more information about the `__asm` keyword.

Example 6 in that section shows how in combination with the `inline` keyword an intrinsic function is created.

3.9.2 INTERRUPT AND TRAP FUNCTIONS

The TriCore C compiler supports a number of function qualifiers and keywords to program interrupt service routines (ISR) or trap handlers. Trap handlers may also be defined by the operating system if your target system uses one.

An *interrupt service routine* (or: interrupt function, or: interrupt handler) is called when an interrupt event (or: *service request*) occurs. This is always an external event; peripherals or external inputs can generate an interrupt signals to the CPU to request for service.

Unlike other interrupt systems, each interrupt has a unique *interrupt request priority number* (IRPN). This number is (0 to 255) is set as the *pending interrupt priority number* (PIPn) in the interrupt control register (ICR) by the interrupt control unit. If multiple interrupts occur at the same time, the priority number of the request with the highest priority is set, so this interrupt is handled.

The TriCore vector table provides an entry for each pending interrupt priority number, not for a specific interrupt source. A request is handled if the priority number is higher then the CPU priority number (CCPN). An interrupt service routine can be interrupted again by another interrupt request with a higher priority. Interrupts with priority number 0 are never handled.

A *trap service routine* (or: trap function, or: trap handler) is called when a trap event occurs. This is always an event generated within or by the application. For example, a divide by zero or an invalid memory access.

With the following function qualifiers you can declare an interrupt handler or trap handler:

```
__interrupt()   __interrupt_fast()
__trap()       __trap_fast()
```

There is one special type of trap function which you can call manually, the system call exception (trap class 6). See section 3.9.2.3, *Defining a Trap Service Routine Class 6*.

```
__syscallfunc()
```

During the execution of an interrupt service routine or trap service routine, the system blocks the CPU from taking further interrupt requests. With the following keywords you can enable interrupts again, immediately after an interrupt or trap function is called:

```
__enable_      __bISR_()
```

3.9.2.1 DEFINING AN INTERRUPT SERVICE ROUTINE

Interrupt functions cannot accept arguments and do not return anything:

```
void __interrupt( vector ) isr( void )
{
  ...
}
```

The argument *vector* identifies the entry into the interrupt vector table (0..255). Unlike other interrupt systems, the priority number (PIPn) of the interrupt now being serviced by the CPU identifies the entry into the vector table.



For an extensive description of the TriCore interrupt system, see the *TriCore 1 Unified Processor Core v1.3 Architecture Manual, Doc v1.3.3* [2002–09, Infineon]

The compiler generates an interrupt service frame for interrupts. The difference between a normal function and an interrupt function is that an interrupt function ends with an **RFE** instruction instead of a **RET**, and that the lower context is saved and restored with a pair of **SVLCX** / **RSLCX** instructions when one of the lower context registers is used in the interrupt handler.

When you define an interrupt service routine with the `__interrupt()` qualifier, the compiler generates an entry for the interrupt vector table. This vector jumps to the interrupt handler.

When you define an interrupt service routine with the `__interrupt_fast()` qualifier, the interrupt handler is directly placed in the interrupt vector table, thereby eliminating the jump code. You should only use this when the interrupt handler is very small, as there is only 32 bytes of space available in the vector table. The compiler does not check this restriction.

Example

The next example illustrates the function definition for a function for a software interrupt with vector number 0x30:

```
int c;  
  
void __interrupt( 0x30 ) transmit( void )  
{  
    c = 1;  
}
```

3.9.2.2 DEFINING A TRAP SERVICE ROUTINE

The definition of a trap service routine is similar to the definition of an interrupt service routine. Trap functions cannot accept arguments and do not return anything:

```
void __trap( class ) tsr( void )  
{  
    ...  
}
```

The argument *class* identifies the entry into the trap vector table. TriCore defines eight classes of trap functions. Each class has its own trap handler.

When a trap service routine is called, the `d15` register contains the so-called *Trap Identification Number* (TIN). This number identifies the cause of the trap. In the trap service routine you can test and branch on the value in `d15` to reach the sub-handler for a specific TIN.

The next table shows the classes supported by TriCore.

Class	Description
Class 0	Reset
Class 1	Internal Protection Traps
Class 2	Instruction Errors
Class 3	Context Management
Class 4	System Bus and Peripheral Errors
Class 5	Assertion Traps
Class 6	System Call
Class 7	Non-Maskable Interrupt



For a complete overview of the trap system and the meaning of the trap identification numbers, see the *TriCore 1 Unified Processor Core v1.3 Architecture Manual, Doc v1.3.3* [2002-09, Infineon]

Analogous to interrupt service routines, the compiler generates a trap service frame for interrupts.

When you define a trap service routine with the `__trap()` qualifier, the compiler generates an entry for the interrupt vector table. This vector jumps to the trap handler.

When you define a trap service routine with the `__trap_fast()` qualifier, the trap handler is directly placed in the trap vector table, thereby eliminating the jump code. You should only use this when the trap handler is very small, as there is only 32 bytes of space available in the vector table. The compiler does not check this restriction.

3.9.2.3 DEFINING A TRAP SERVICE ROUTINE CLASS 6:

__syscallfunc()

A special kind of trap service routine is the system call trap. With a system call the trap service routine of class 6 is called. For the system call trap, the trap identification number (TIN) is taken from the immediate constant specified with the function qualifier `__syscallfunc()`:

```
__syscallfunc(TIN)
```

The TIN is a value in the range 0 and 255. You can only use `__syscallfunc()` in the function declaration. A function body is useless, because when you call the function declared with `__syscallfunc()`, a trap class 6 occurs which calls the corresponding trap service routine.



In case of the other traps, when a trap service routine is called, the *system* places a trap identification number in `d15`.

Unlike the other traps, a class 6 trap service routine can contain arguments and return a value. Arguments that are passed via the stack, remain on the stack of the caller because it is not possible to pass arguments from the user stack to the interrupt stack on a system call. This restriction, caused by the TriCore's run-time behavior, cannot be checked by the compiler.

The next example illustrates the definition of a class 6 trap service routine and the corresponding system call:

Example

```
__syscallfunc(1) int syscall_a( int, int );
__syscallfunc(2) int syscall_b( int, int );

int x;

void main( void )
{
    x = syscall_a(1,2);    // causes a trap class 6 with TIN = 1
    x = syscall_b(4,3);    // causes a trap class 6 with TIN = 2
}

int __trap( 6 ) trap6( int a, int b ) // trap class 6 handler
{
    int tin;
    __asm("mov %0,d15" : "=d"(tin)); // put d15 in C variable tin

    switch( tin )
    {
    case 1:
        a += b;
        break;
    case 2:
        a -= b;
        break;
    default:
        break;
    }
    return a;
}
```

3.9.2.4 ENABLING INTERRUPT REQUESTS: `__enable_`, `__bisr_()`

Enabling interrupt service requests

During the execution of an interrupt service routine or trap service routine, the system blocks the CPU from taking further interrupt requests. You can immediately re-enable the system to accept interrupt requests:

```
__interrupt(vector) __enable_ isr( void )
__trap(class) __enable_ tsr( void )
```

The compiler generates an `enable` instruction as first instruction in the routine. The `enable` instruction sets the interrupt enable bit (ICR.IE) in the interrupt control register.

You can also generate the `enable` instruction with the `__enable()` intrinsic function, but it is not guaranteed that it will be the *first* instruction in the routine.

Enabling interrupt service requests and setting CPU priority number

The function qualifier `__bisr_()` also re-enables the system to accept interrupt requests. In addition, the *current CPU priority number* (CCPN) in the interrupt control register is set:

```
__interrupt(vector) __bisr_(CCPN) isr( void )
__trap(class) __bisr_(CCPN) tsr( void )
```

The argument *CCPN* is a number between 0 and 255. The system accepts all interrupt requests that have a higher pending interrupt priority number (PIPn) than the current CPU priority number. So, if the CPU priority number is set to 0, the system accepts all interrupts. If it is set to 255, no interrupts are accepted.

The compiler generates a `bisr` instruction as first instruction in the routine. The `bisr` instruction sets the interrupt enable bit (ICR.IE) and the current CPU priority number (ICR.CCPN) in the interrupt control register.

You can also generate the `bisr` instruction with the `__bisr()` intrinsic function, but it is not guaranteed that it will be the *first* instruction in the routine.

Setting the CPU priority number in a Class 6 trap service routine

The `bisr` instruction saves the lower context so passing and returning arguments is not possible. Therefore, you cannot use the function qualifier `__bisr_()` for class 6 traps.

Instead, you can use the function qualifier `__enable_` to set the ICR.IE bit, and the intrinsic function `__mtr(int, int)` to set the ICR.CCPN value at the beginning of a class 6 trap service routine (or use the intrinsic function `__mtr_()` to set both the ICR.IE bit and the ICR.CCPN value).

3.9.3 FUNCTION CALLING MODES: `__indirect`

Functions are default called with a single word direct call. However, when you link the application and the target address appears to be out of reach (± 16 MB from the `callg` or `jg` instruction), the linker generates an error. In this case you can use the `__indirect` keyword to force the less efficient, two and a half word indirect call to the function:

```
int __indirect foo( void )
{
...
}
```

With compiler option `--indirect` you tell the compiler to generate far calls for *all* functions.

3.9.4 PARAMETER PASSING AND THE STACK MODEL: `__stackparm`

The parameter registers D4..D7 and A4..A7 are used to pass the initial function arguments. Up to 4 arithmetic types and 4 pointers can be passed this way. A 64-bit argument is passed in an even/odd data register pair. Parameter registers skipped because of alignment for a 64-bit argument are used by subsequent 32-bit arguments. Any remaining function arguments are passed on the stack. Stack arguments are pushed in reversed order, so that the first one is at the lowest address. On function entry, the first stack parameter is at the address (SP+0).

```
void func1( int i, char *p, char c );           /* D4 A4 D5 */
void func2( int i1, double d, int i2 );       /* D4 E6 D5 */
void func3( char c1, char c2, char c3[] );    /* D4 D5 A4 */
```

```
void func4( double d1, int i1, double d2, int i2 );
/* E4 D6 stack D7 */
```

All function arguments passed on the stack are aligned on a multiple of 4 bytes. As a result, the stack offsets for all types except `float` are compatible with the stack offsets used by a function declared without a prototype.

Structures up to eight bytes are passed via a data register or data register pair. Larger structures are passed via the stack.

Arithmetic function results of up to 32 bits are returned in the D2 register. 64-bit arithmetic types are returned in the register pair D2/D3 (E2). Pointers are returned in A2, and circular pointers are returned in A2/A3.

When the function return type is a structure, it is copied to a "return area" that is allocated by the caller. The address of this area is passed as an implicit first argument in A4.

The following table summarize the registers used by the TriCore compiler **ctc**:

Register		Usage	Register	Usage
D0	E0	scratch	A0	global
D1		scratch	A1	global
D2	E2	return register for arithmetic types	A2	return register for pointers
D3		most significant part of 64 bit result	A3	scratch
D4	E4	parameter	A4	parameter
D5		parameter	A5	parameter
D6	E6	parameter	A6	parameter
D7		parameter	A7	parameter
D8	E8	saved register	A8	global
D9		saved register	A9	global
D10	E10	saved register	A10	stack pointer
D11		saved register	A11	link register
D12	E12	saved register	A12	saved register
D13		saved register	A13	saved register

Register		Usage	Register	Usage
D14		saved register	A14	saved register
D15	E14	saved register, implicit register	A15	saved register, implicit pointer

Table 3-9: Register usage

Stack Model: `__stackparm`

The function qualifier `__stackparm` changes the standard calling convention of a function into a convention where all function arguments are passed via the stack, conforming to a so-called stack model. This qualifier is only needed for situations where you need to use an indirect call to a function for which you do not have a valid prototype.

The compiler sets the least significant bit of the function pointer when you take the address of a function declared with the `__stackparm` qualifier, so that these function pointers can be identified at run-time. The least significant bit of a function pointer address is ignored by the hardware.

Example

```

void          plain_func ( int );
void __stackparm stack_func ( int );

void call_indirect ( unsigned int fp, int arg )
{
    typedef __stackparm void (*SFP)( int );
    typedef void (*RFP)( int );

    SFP    fp_stack;
    RFP    fp_reg;

    if ( fp & 1 )
    {
        fp_stack = (SFP) fp;
        fp_stack( arg );
    }
    else
    {
        fp_reg = (RFP) fp;
        fp_reg( arg );
    }
}

```

```
void main ( void )
{
    call_indirect( (unsigned int) plain_func, 1 );
    call_indirect( (unsigned int) stack_func, 2 );
}
```

3.10 COMPILER GENERATED SECTIONS

The compiler generates code and data in several types of sections. The compiler uses the following section naming convention:

section_type_prefix.module_name.symbol_name

The prefix depends on the type of the section and determines if the section is initialized, constant or uninitialized and which addressing mode is used. The *symbol_name* is either the name of an object or the name of a function.

Type	Name prefix	Description
code	.text	program code
neardata	.zdata	initialized __near data
fardata	.data	initialized __far data
nearrom	.zrodata	constant __near data
farrom	.rodata	constant __far data
nearbss	.zbss	uninitialized __near data (cleared)
farbss	.bss	uninitialized __far data (cleared)
nearnoclear	.zbss	uninitialized __near data
farnoclear	.bss	uninitialized __far data
a0data	.sdata	initialized __a0 data
a0rom	.srodata	constant __a0 data
a0bss	.sbss	uninitialized __a0 data (cleared)
a1rom	.ldata	constant __a1 data
a8data	.data_a8	initialized __a8 data
a8rom	.rodata_a8	constant __a8 data
a8bss	.bss_a8	uninitialized __a8 data (cleared)
a9data	.data_a9	initialized __a9 data
a9rom	.rodata_a9	constant __a9 data
a9bss	.bss_a9	uninitialized __a9 data (cleared)

Table 3-10: Section types and name prefixes

Rename sections

You can change the default section names with one of the following pragmas:

```
#pragma section type "string"
```

All sections of the specified *type* will be named "*prefix.string*". For example,

```
#pragma section neardata "where"
```

all sections of type neardata have the name ".zdata.where".

#pragma section type will restore the default section naming for sections of this type.

#pragma section type restore will restore the previous setting of **#pragma section type**.

```
#pragma section all "string"
```

All sections will be named "*prefix.string*", unless you use a type specific renaming pragma. For example,

```
#pragma section all "here"
```

all sections have the syntax "*prefix.here*". For example, sections of type neardata have the name ".zdata.here".

#pragma section all will restore the default section naming (not for sections that have a type specific renaming pragma).

#pragma section all restore will restore the previous setting of **#pragma section all**.

Example:

```
#pragma section all "rename_1"  
// .text.rename_1  
// .data.rename_1  
  
#pragma section code "rename_2"  
// .text.rename_2  
// .data.rename_1
```



See also compiler option **-R** in section *Compiler Options* in Chapter *Tool Options of the Reference Manual*.

Influence section definition

The following pragmas also influence the section definition:

```
#pragma section code_init
```

Code sections are copied from ROM to RAM at program startup.

```
#pragma section const_init
```

Sections with constant data are copied from ROM to RAM at program startup.

```
#pragma section vector_init
```

Sections with interrupts and trap vectors are copied from ROM to RAM at program startup.

```
#pragma section data_overlay
```

The `nearnoclear` and `farnoclear` sections can be overlaid by other sections with the same name. Since default section naming never leads to sections with the same name, you must force the same name by using one of the section renaming pragmas. To get noclear sections instead of BSS sections you must also use **#pragma noclear**.

3.11 SWITCH STATEMENT

ctc supports three ways of code generation for a switch statement: a jump chain (linear switch), a jump table or a lookup table.

A *jump chain* is comparable with an if/else-if/else-if/else construction. A *jump table* is a table filled with target addresses for each possible switch value. The switch argument is used as an index within this table. A *lookup table* is a table filled with a value to compare the switch argument with and a target address to jump to. A binary search lookup is performed to select the correct target address.

By default, the compiler will automatically choose the most efficient switch implementation based on code and data size and execution speed. You can influence the selection of the switch method with compiler option **-t** (**--tradeoff**), which determines the speed/size tradeoff.

It is obvious that, especially for large switch statements, the jump table approach executes faster than the lookup table approach. Also the jump table has a predictable behavior in execution speed. No matter the switch argument, every case is reached in the same execution time. However, when the case labels are distributed far apart, the jump table becomes sparse, wasting code memory. The compiler will not use the jump table method when the waste becomes excessive.

With a small number of cases, the jump chain method can be faster in execution and shorter in size.

How to overrule the default switch method

You can overrule the compiler chosen switch method with a pragma:

```
#pragma switch linear      /* force jump chain code */
#pragma switch jumptab    /* force jump table code */
#pragma switch lookup     /* force lookup table code */
#pragma switch auto       /* let the compiler decide
                           the switch method used */
#pragma switch restore    /* restore previous switch
                           method */
```

Pragma `switch auto` is also the default of the compiler.

On the command line you can use compiler option **--switch**.

3.12 LIBRARIES

The compiler **ctc** comes with standard C libraries (ISO/IEC 9899:1999) and header files with the appropriate prototypes for the library functions. The standard C libraries are available in object format and in C or assembly source code.

A number of standard operations within C are too complex to generate inline code for. These operations are implemented as *run-time* library functions.

The lib directory contains subdirectories with separate libraries for the TriCore 1 and the TriCore 2. Furthermore, protected libraries are available for the TC112 and TC113 functional problems.

The protected library sets provide software bypasses for all TC112 and TC113 supported CPU functional problems. They must be used in conjunction with the appropriate C compiler workarounds for CPU functional problems. For more details refer to Chapter 9, *CPU Functional Problems* in the *Reference Manual*.

The directory structure is:

```
\ctc\lib\  
    tc1\           TriCore 1 libraries  
    tc2\           TriCore 2 libraries  
    p\  
        tc112      Protected libraries for TC112 problems  
        tc113      Protected libraries for TC113 problems
```

3.12.1 OVERVIEW OF LIBRARIES

Table 3-11 lists the libraries included in the TriCore (**ctc**) toolchain.

Library to link	Description
libc.a	C library (Some functions require the floating-point library. Also includes the startup code.)
libcs.a	C library single precision (compiler option -F) (Some functions require the floating-point library. Also includes the startup code.)
libcs_fpu.a	C library single precision with FPU instructions (compiler option -F and --fpu-present)
libfp.a	Floating-point library (non-trapping)
libfpt.a	Floating-point library (trapping) (Control program option --fp-trap)
libfp_fpu.a	Floating-point library (non-trapping, with FPU instructions) (Compiler option --fpu-present)
libfpt_fpu.a	Floating-point library (trapping, with FPU instructions) (Control program option --fp-trap , compiler option --fpu-present)
librt.a	Run-time library

Table 3-11: Overview of libraries



See section 2.2, *Library Functions*, in Chapter *Libraries* of the *Reference Manual* for an extensive description of all standard C library functions.

3.12.2 PRINTF AND SCANF FORMATTING ROUTINES

The C library functions `printf()`, `fprintf()`, `vfprintf()`, `vsprintf()`, ... call one single function, `_doprint()`, that deals with the format string and arguments. The same applies to all `scanf` type functions, which call the function `_doscan()`, and also for the `wprintf` and `wscanf` type functions which call `_dowprint()` and `_dowscan()` respectively. The C library contains three versions of these routines: `int`, `long` and `long long` versions. If you use floating-point, the formatter function for floating-point `_doflt()` or `_dowflt()` is called. Depending on the formatting arguments you use, the correct routine is used from the library. Of course the larger the version of the routine the larger your produced code will be.

Note that when you call any of the `printf/scanf` routines indirect, the arguments are not known and always the `long long` version with floating-point support is used from the library.

Example:

```
#include <stdio.h>

long L;

void main(void)
{
    printf( "This is a long: %ld\n", L );
}
```

The linker extracts the `long` version without floating-point support from the library.

Fixed point format specifiers

The `printf` and `scanf` type functions support two additional format specifiers for the conversion of fixed-point types (fractional and accumulator types).

For `printf` type functions:

- `%lR` An `__laccum` argument representing a fixed-point accumulator number is converted to decimal notation in the style `[-]ddd.ddd`, where the number of digits after the decimal-point character is equal to the precision specification.
- `%r` A `__fract` argument representing a fixed-point fractional number is converted to decimal notation in the style `[-]d.ddd`, where there is one digit (which is non-zero if the argument is `-1.0`) before the decimal point character and the number of digits after it is equal to the precision.

For `scanf` type functions:

- `%lR` Matches an optionally signed fixed-point accumulator number. The corresponding argument shall be a pointer to `__laccum`.
- `%r` Matches an optionally signed fixed-point fractional number. The corresponding argument shall be a pointer to `__fract`.

Example:

```
#include <stdio.h>

__fract  fvalue = 1.0/3;
__laccum lacvalue = 1.234;

void main(void)
{
    printf("fvalue is: %r\n", fvalue);
    printf("lacvalue is: %lR\n", lacvalue);
}
```

3.12.3 REBUILDING LIBRARIES

If you have manually changed one of the standard C library functions, you need to recompile the standard C libraries.



'Weak' symbols are used to extract the most optimal implementation of a function from the library. For example if your application does not use floating-point variables the printf alike functions do not support floating-point types either. The compiler emits strong symbols to guide this process. Do not change the order in which modules are placed in the library since this may break this process.

The sources of the libraries are present in the `lib\src` directory. This directory also contains subdirectories with a `makefile` for each type of library:

```

lib\src\
  p\
    tc112\
      libc\makefile
      libcs\makefile
      libcs_fpu\makefile
    tc113\
      libc\makefile
      libcs\makefile
      libcs_fpu\makefile
  tc1\
    libc\makefile
    libcs\makefile
    libcs_fpu\makefile
  tc2\
    libc\makefile
    libcs\makefile
    libcs_fpu\makefile

```

To rebuild the libraries, follow the steps below.

First make sure that the `bin` directory for the TriCore toolchain is included in your `PATH` environment variable. (See section 1.3.2, *Configuring the Command Line Environment*.)

1. Make the directory `lib\src\tc2\libc` the current working directory.

This directory contains a `makefile` which also uses the default make rules from `mktc.mk` from the `etc\etc` directory.

2. Edit the `makefile`.



See section 8.3, *Make Utility*, in Chapter *Utilities* for an extensive description of the `make` utility and `makefiles`.

3. Assuming the `lib\src\tc2\libc` directory is still the current working directory, type:

```
mktc
```

to build the library.

The new library is created in the `lib\src\tc2\libc` directory.

4. Make a backup copy of the original library and copy the new library to the `lib\tc2` directory of the product.

C LANGUAGE

CHAPTER

4

TRICORE ASSEMBLY LANGUAGE

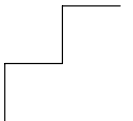

4 | CHAPTER

4.1 INTRODUCTION

In this chapter the most important aspects of the TriCore assembly language are described. For a complete overview of the TriCore2 architecture, refer to the *TriCore2 Architecture Overview Handbook* [2002, Infineon].

4.2 ASSEMBLY SYNTAX

An assembly program consists of zero or more statements. A statement may optionally be followed by a comment. Any source statement can be extended to more lines by including the line continuation character (\) as the last character on the line. The length of a source statement (first line and continuation lines) is only limited by the amount of available memory.

Mnemonics and directives are case insensitive. Labels, symbols, directive arguments, and literal strings are case sensitive.

The syntax of an assembly *statement* is:

`[label[:]] [instruction | directive | macro_call] [:comment]`

label A label is a special symbol which is assigned the value and type of the current program location counter. A label can consist of letters, digits and underscore characters (`_`). The first character cannot be a digit. A label which is prefixed by whitespace (spaces or tabs) has to be followed by a colon (`:`). The size of an identifier is only limited by the amount of available memory.

Examples:

```
LAB1: ; This label is followed by a colon and  
      ; can start with a space or tab  
LAB1  ; This label has to start at the beginning  
      ; of a line
```

instruction An instruction consists of a mnemonic and zero, one or more operands. It must not start in the first column. Operands are described in section 4.4, *Operands of an Assembly Instruction*. The instructions are described in the *TriCore Architecture Manuals*.

Examples:

```
ret                ; No operand
call   label      ; One operand
mov    D0,#1      ; Two operands
jne    D0,#0,loop ; Three operands
madd   D2,D3,D0,D1 ; Four operands
insert D1,D2,#3,#16,#2 ; Five operands
```

directive With directives you can control the assembler from within the assembly source. These must not start in the first column. Directives are described in section 4.8, *Assembler Directives and Controls*.

macro_call A call to a previously defined macro. It must not start in the first column. Macros are described in section 4.10 *Macro Operations*.

You can use empty lines or lines with only comments.

Apart from the assembly statements as described above, you can put a so-called 'control line' in your assembly source file. These lines start with a \$ in the first column and alter the default behavior of the assembler.

\$control

For more information on controls see section 4.8, *Assembler Directives and Controls*.

4.3 ASSEMBLER SIGNIFICANT CHARACTERS

You can use all ASCII characters in the assembly source both in strings and in comments. Also the extended characters from the ISO 8859-1 (Latin-1) set are allowed.

Some characters have a special meaning to the assembler. Special characters associated with expression evaluation are described in section 4.6.3, *Expression Operators*. Other special assembler characters are:

Character	Description
;	Start of a comment
\	Line continuation character or Macro operator: argument concatenation
?	Macro operator: return decimal value of a symbol
%	Macro operator: return hex value of a symbol
^	Macro operator: override local label
"	Macro string delimiter or Quoted string .DEFINE expansion character
'	String constants delimiter
@	Start of a built-in assembly function
*	Location counter substitution
#	Constant number
++	String concatenation operator
[]	Substring delimiter

4.4 OPERANDS

In an instruction, the mnemonic is followed by zero, one or more operands. An operand has one of the following types:

Operand	Description
<i>symbol</i>	A symbolic name as described in section 4.5, <i>Symbol Names</i> . Symbols can also occur in expressions.
<i>register</i>	Any valid register or a register pair, register quad, register extension, register part or special function register.
<i>expression</i>	Any valid expression as described in the section 4.6, <i>Assembly Expressions</i> .
<i>address</i>	A combination of <i>expression</i> , <i>register</i> and <i>symbol</i> .

4.4.1 OPERANDS AND ADDRESSING MODES

The TriCore assembly language has several addressing modes. These are listed below with a short description. For details see the *TriCore 1 Unified Processor Core v1.3 Architecture Manual, Doc v1.3.3* [2002-09, Infineon]

Absolute addressing

The instruction uses an 18-bit constant as the memory address. The full 32-bit address results from moving the most significant 4 bits of the 18-bit constant to the most significant bits of the 32-bit address. The other bits are zero filled.

Syntax:

constant18

Base+offset

The effective address is the sum of an address register and the sign-extended 10-bit or 16-bit offset.

Syntax:

[An]offset10
[An]offset16

Pre-increment/decrement

This addressing mode uses the sum of the address register and the offset both as the effective address and as the value written back into the address register. Use the minus sign for a pre-decrement.

Syntax:

[+An]offset10

Post-increment/decrement

This addressing mode uses the value of the address register as the effective address, and then updates this register by adding the sign-extended 10-bit offset to its previous value. Use the minus sign for a post-decrement.

Syntax:

[An+]offset10

Circular addressing

This addressing mode is used for accessing data values in circular buffers. It uses an address register pair to hold the state it requires. The even register is always a base address (B). The most-significant half of the odd register is the buffer size (L). The least significant half holds the index into the buffer (I). The effective address is (B+I). The buffer occupies memory from addresses B to B+L-1. The 10-bit offset is specified in the instruction word and is a byte-offset that can be either positive or negative.

Syntax:

$$[An+c]offset10$$

Bit-reverse addressing

Bit reverse addressing is used to access arrays used in FFT algorithms. Bit-reverse addressing uses an address register pair to hold the required state. The even register is the base address of the array (B), the least-significant half of the odd register is the index into the array (I), and the most-significant half is the modifier (M) which is added to I after every access. The effective address is B+reverse(I). The reverse() function exchanges bit n with bit (15-n) for n = 0, ..., 7. The index, I, is post-incremented and its new value is (I + M), where M is the most significant half of the odd register.

Syntax:

$$[An+r]$$

Indexed addressing

The indexed addressing mode uses an address register pair to hold the required state. The A_{even} register is the base address of the array (B). The A_{odd} register is divided equally between the index into the array (I), and the modifier (N) which is added to I after every access.

A _{odd}	N	I
A _{even}	B	

All load (LD.xxx) instructions, all store(ST.xxx except ST.T) instructions, the load/modify/store (SWAP.W,LDMST) instructions and the cache management (CACHEA.xxx) instructions are able to use the indexed addressing mode.

Syntax:

[Aa/Ab+i]

ld.w d0,[a0/a1+i] ; load word indexed addressing mode
 st.w [a2/a3+i],d0 ; store word indexed addressing mode

4.4.2 PCP ADDRESSING MODES

The PCP assembly language has several addressing modes. These addressing modes are used for FPI addressing, PRAM data indirect addressing or flow control destination addressing. For details see the PCP/DMA Architecture manual from Siemens.

4.5 SYMBOL NAMES

User-defined symbols

A user-defined *symbol* can consist of letters, digits and underscore characters (_). The first character cannot be a digit. The size of an identifier is only limited by the amount of available memory. The case of these characters is significant. You can define a symbol by means of a label declaration or an equate or set directive.

Labels

Symbols used for memory locations are referred to as labels.

Reserved symbols

Register names and names of assembler directives and controls are reserved for the system, so you cannot use these for user-defined symbols. The case of these built-in symbols is insignificant. Symbol names and other identifiers beginning with a period (.) are also reserved for the system.

The following symbols are predefined:

Symbol	Description
<code>__ASTC__</code>	Contains the name of the assembler ("astc")
<code>__ASPCP__</code>	Contains the name of the PCP assembler ("aspcp")
<code>__FPU__</code>	Defined when you use assembler option <code>--fpu-present</code> (allow use of FPU instructions)
<code>__MMU__</code>	Defined when you use assembler option <code>--mmu-present</code> (allow use of MMU instructions)
<code>__TC2__</code>	Defined when you use assembler option <code>--is-tricore2</code> (allow use of TriCore 2 instructions)

Table 4-1: Predefined symbols

Examples

Valid symbol names	Invalid symbol names
<code>loop_1</code>	<code>1_loop</code> (starts with a number)
<code>ENTRY</code>	<code>d15</code> (reserved register name)
<code>a_B_c</code>	<code>.space</code> (reserved directive name)
<code>_aBC</code>	

4.6 ASSEMBLY EXPRESSIONS

An expression is a combination of symbols, constants, operators, and parentheses which represent a value that is used as an operand of an assembler instruction (or directive).

Expressions can contain user-defined labels (and their associated integer or floating-point values), and any combination of integers, floating-point numbers, or ASCII literal strings.

Expressions follow the conventional rules of algebra and boolean arithmetic.

Expressions that can be evaluated at assembly time are called *absolute expressions*. Expressions where the result is unknown until all sections have been combined and located, are called *relocatable* or *relative expressions*.

When any operand of an expression is relocatable, the entire expression is relocatable. Relocatable expressions are emitted in the object file and are evaluated by the linker. Relocatable expressions can only contain integral functions; floating-point functions and numbers are not supported by the ELF/DWARF object format.

The assembler evaluates expressions with 64-bit precision in two's complement.

The syntax of an *expression* can be any of the following:

- *numeric constant*
- *string*
- *symbol*
- *expression binary_operator expression*
- *unary_operator expression*
- *(expression)*
- *function call*

All types of expressions are explained in separate sections.

4.6.1 NUMERIC CONSTANTS

Numeric constants can be used in expressions. If there is no prefix, the assembler assumes the number is a decimal number.

Base	Description	Example
Binary	'0B' or '0b' followed by binary digits (0,1).	0B1101 0b11001010
Hexadecimal	'0X' or '0x' followed by a hexadecimal digits (0-9, A-F, a-f).	0X12FF 0x45 0x9abc
Decimal, integer	Decimal digits (0-9).	12 1245
Decimal, floating-point	Includes a decimal point, or an 'E' or 'e' followed by the exponent.	6E10 .6 3.14 2.7e10

4.6.2 STRINGS

ASCII characters, enclosed in single (') or double (") quotes constitute an ASCII string. Strings between double quotes allow symbol substitution by a `.DEFINE` directive, whereas strings between single quotes are always literal strings. Both types of strings can contain escape characters.

Strings constants in expressions are evaluated to a number (each character is replaced by its ASCII value). Strings in expressions can have the size of a long word (first 4 characters) or less depending on the operand of an instruction or directive; any subsequent characters in the string are ignored. In this case the assembler issues a warning. An exception to this rule is when a string longer than 4 characters is used in a `.BYTE` assembler directive; in that case all characters result in a constant byte. Null strings have a value of 0.

Square brackets (`[]`) delimit a substring operation in the form:

`[string,offset,length]`

offset is the start position within *string*. *length* is the length of the desired substring. Both values may not exceed the size of *string*.

Examples

```
'ABCD'           ; (0x41424344)
'''79'          ; to enclose a quote double it
"A\"BC"         ; or to enclose a quote escape it
'AB'+1          ; (0x00004143) string used in expression
''              ; null string
.word 'abcdef'  ; (0x64636261) 'ef' are ignored
                ; warning: string value truncated
'abc'++'de'     ; you can concatenate
                ; two strings with the '++' operator.
                ; This results in 'abcde'
['TriCore',0,3] ; results in the substring 'Tri'
```

4.6.3 EXPRESSION OPERATORS

The next table shows the assembler operators. They are ordered according to their precedence. Operators of the same precedence are evaluated left to right. Expressions between parentheses have the highest priority (innermost first).

Valid operands include numeric constants, literal ASCII strings and symbols.

Most assembler operators can be used with both integer and floating-point values. If one operand has an integer value and the other operand has a floating-point value, the integer is converted to a floating-point value before the operator is applied. The result is a floating-point value.

Type	Operator	Name	Description
	()	parentheses	Expressions enclosed by parenthesis are evaluated first.
Unary	+	plus	Returns the value of its operand.
	-	minus	Returns the negative of its operand.
	~	complement	Returns complement, integer only
	!	logical negate	Returns 1 if the operands' value is 1; otherwise 0. For example, if <code>buf</code> is 0 then <code>!buf</code> is 1.
Arithmetic	*	multiplication	Yields the product of two operands.
	/	division	Yields the quotient of the division of the first operand by the second. With integers, the divide operation produces a truncated integer.
	%	modulo	Integer only: yields the remainder from a division of the first operand by the second.
	+	addition	Yields the sum of its operands.
	-	subtraction	Yields the difference of its operands.

Type	Operator	Name	Description
Shift	<<	shift left	Integer only: shifts the left operand to the left (zero-filled) by the number of bits specified by the right operand.
	>>	shift right	Integer only: shifts the left operand to the right (sign bit extended) by the number of bits specified by the right operand.
Relational	<	less than	If the indicated condition is: – True: result is an integer 1 – False: result is an integer 0
	<=	less or equal	
	>	greater than	Be cautious when you use floating-point values in an equality test; rounding errors can cause unexpected results.
	>=	greater or equal	
	==	equal	
	!=	not equal	
Bitwise	&	AND	Integer only: yields bitwise AND
		OR	Integer only: yields bitwise OR
	^	exclusive OR	Integer only: yields bitwise exclusive OR
Logical	&&	logical AND	Returns an integer 1 if both operands are nonzero; otherwise, it returns an integer 0.
		logical OR	Returns an integer 1 if either of the operands is nonzero; otherwise, it returns an integer 1

Table 4-2: Assembly expression operators

4.7 BUILT-IN ASSEMBLY FUNCTIONS

The assembler has several built-in functions to support data conversion, string comparison, and math computations. You can use functions as terms in any expression. Functions have the following syntax:

Syntax of an assembly function

`@function_name([argument[,argument]...])`

Functions start with the '@' character and have zero or more arguments, and are always followed by opening and closing parentheses. White space (a blank or tab) is not allowed between the function name and the opening parenthesis and between the (comma-separated) arguments.

The built-in assembler functions are grouped into the following types:

- **Mathematical functions** comprise, among others, transcendental, random value, and min/max functions.
- **Conversion functions** provide conversion between integer, floating-point, and fixed point fractional values.
- **String functions** compare strings, return the length of a string, and return the position of a substring within a string.
- **Macro functions** return information about macros.
- **Address calculation functions** return the high or low part of an address.
- **Assembler mode functions** relating assembler operation.

The following tables provide an overview of all built-in assembler functions. For a detailed description of these functions, see section 3.2, *Built-in Assembly Function*, in Chapter *Assembly Language* of the *Reference Manual*.

Overview of mathematical functions

Function	Description
@ABS(<i>expr</i>)	Absolute value
@ACS(<i>expr</i>)	Arc cosine
@ASN(<i>expr</i>)	Arc sine
@AT2(<i>expr1,expr2</i>)	Arc tangent
@ATN(<i>expr</i>)	Arc tangent
@CEL(<i>expr</i>)	Ceiling function
@COH(<i>expr</i>)	Hyperbolic cosine
@COS(<i>expr</i>)	Cosine
@FLR(<i>expr</i>)	Floor function
@L10(<i>expr</i>)	Log base 10
@LOG(<i>expr</i>)	Natural logarithm
@MAX(<i>expr</i> , [...], <i>exprN</i>)	Maximum value
@MIN(<i>expr</i> , [...], <i>exprN</i>)	Minimum value
@POW(<i>expr1,expr2</i>)	Raise to a power
@RND()	Random value
@SGN(<i>expr</i>)	Returns the sign of an expression as -1, 0 or 1
@SIN(<i>expr</i>)	Sine
@SNH(<i>expr</i>)	Hyperbolic sine
@SQT(<i>expr</i>)	Square root
@TAN(<i>expr</i>)	Tangent
@TNH(<i>expr</i>)	Hyperbolic tangent
@XPN(<i>expr</i>)	Exponential function (raise e to a power)

Overview of conversion functions

Function	Description
@CVF(<i>expr</i>)	Convert integer to floating-point
@CVI(<i>expr</i>)	Convert floating-point to integer
@FLD(<i>base,value,width[,start]</i>)	Shift and mask operation
@FRACT(<i>expr</i>)	Convert floating-point to 32-bit fractional
@SFRACT(<i>expr</i>)	Convert floating-point to 16-bit fractional
@LNG(<i>expr</i>)	Concatenate to double word
@LUN(<i>expr</i>)	Convert long fractional to floating-point
@RVB(<i>expr1[,expr2]</i>)	Reverse order of bits in field
@UNF(<i>expr</i>)	Convert fractional to floating-point

Overview of string functions

Function	Description
@CAT(<i>str1,str2</i>)	Concatenate strings
@LEN(<i>string</i>)	Length of string
@POS(<i>str1,str2[,start]</i>)	Position of substring in string
@SCP(<i>str1,str2</i>)	Returns 1 if two strings are equal
@SUB(<i>string,expr,expr</i>)	Returns substring in string

Overview of macro functions

Function	Description
@ARG('symbol' <i>expr</i>)	Test if macro argument is present
@CNT()	Return number of macro arguments
@MAC(<i>symbol</i>)	Test if macro is defined
@MXP()	Test if macro expansion is active

Overview of address calculation functions

Function	Description
@HI(<i>expr</i>)	Returns upper 16 bits of expression value
@HIS(<i>expr</i>)	Returns upper 16 bits of expression value, adjusted for signed addition
@LO(<i>expr</i>)	Returns lower 16 bits of expression value
@LOS(<i>expr</i>)	Returns lower 16 bits of expression value, adjusted for signed addition
@LSB(<i>expr</i>)	Get least significant byte of a word
@MSB(<i>expr</i>)	Get most significant byte of a word

Overview of assembler mode functions

Function	Description
@ASPCP()	Returns the name of the PCP assembler executable
@ASTC()	Returns the name of the assembler executable
@CPU(<i>string</i>)	Test if CPU type is selected
@DEF('symbol' <i>symbol</i>)	Returns 1 if symbol has been defined
@EXP(<i>expr</i>)	Expression check
@INT(<i>expr</i>)	Integer check
@LST()	LIST control flag value

4.8 ASSEMBLER DIRECTIVES AND CONTROLS

An assembler directive is simply a message to the assembler. Assembler directives are not translated into machine instructions. There are three main groups of assembler directives.

- Assembler directives that tell the assembler how to go about translating instructions into machine code. This is the most typical form of assembly directives. Typically they tell the assembler where to put a program in memory, what space to allocate for variables, and allow you to initialize memory with data. When the assembly source is assembled, a location counter in the assembler keeps track of where the code and data is to go in memory.

The following directives fall under this group:

- Assembly control directives
- Symbol definition directives
- Data definition / Storage allocation directives
- Debug directives
- Directives that are interpreted by the macro preprocessor. These directives tell the macro preprocessor how to manipulate your assembly code before it is actually being assembled. You can use these directives to write macros and to write conditional source code. Parts of the code that do not match the condition, will not be assembled at all.
- Some directives act as assembler options and most of them indeed do have an equivalent assembler (command line) option. The advantage of using a directive is that with such a directive you can overrule the assembler option for a particular part of the code. Directives of this kind are called *controls*. A typical example is to tell the assembler with an option to generate a list file while with the controls \$LIST ON and \$LIST OFF you overrule this option for a part of the code that you do *not* want to appear in the list file. Controls always appear on a separate line and start with a '\$' sign in the first column.

The following controls are available:

- Assembly listing controls
- Miscellaneous controls

Each assembler directive or control has its own syntax. You can use assembler directives and controls in the assembly code as pseudo instructions.

4.8.1 OVERVIEW OF ASSEMBLER DIRECTIVES

The following tables provide an overview of all assembler directives. For a detailed description, see section 3.3.2, *Detailed Description of Assembler Directives*, in Chapter *Assembly Language* of the *Reference Manual*.

Overview of assembly control directives

Directive	Description
.COMMENT	Start comment lines. You cannot use this directive in .IF/.ELSE/.ENDIF constructs and .MACRO/.DUP definitions.
.DEFINE	Define substitution string
.END	End of source program
.FAIL	Programmer generated error message
.INCLUDE	Include file
.MESSAGE	Programmer generated message
.ORG	Initialize memory space and location counters to create a nameless section
.SDECL	Declare a section with name, type and attributes
.SECT	Activate a declared section
.UNDEF	Undefine .DEFINE symbol
.WARNING	Programmer generated warning

Overview of symbol definition directives

Function	Description
.EQU	Assigns permanent value to a symbol
.EXTERN	External symbol declaration
.GLOBAL	Global symbol declaration
.LOCAL	Local symbol declaration
.SET	Set temporary value to a symbol
.SIZE	Set size of symbol in the ELF symbol table
.TYPE	Set symbol type in the ELF symbol table
.WEAK	Mark symbol as 'weak'

Overview of data definition / storage allocation directives

Function	Description
.ACCUM	Define 64-bit constant in 18 + 46 bits format
.ALIGN	Define alignment
.ASCII / .ASCIIZ	Define ASCII string without / with ending NULL byte
.BYTE	Define constant byte
.FLOAT / .DOUBLE	Define a 32-bit / 64-bit floating-point constant
.FRACT / .SFRACT	Define a 16-bit / 32-bit constant fraction
.SPACE	Define storage
.WORD / .HALF	Define a word / half-word constant

Overview of macro and conditional assembly directives

Function	Description
.DUP	Duplicate sequence of source lines
.DUPA	Duplicate sequence with arguments
.DUPC	Duplicate sequence with characters
.DUPF	Duplicate sequence in loop
.ENDM	End of macro or duplicate sequence
.EXITM	Exit macro
.IF/.ELIF/.ELSE/.ENDIF	Conditional assembly
.MACRO	Define macro
.PMACRO	Undefine (purge) macro

Overview of debug directives

Function	Description
.CALLS	Passes call information to object file. Used by the linker to build a call graph.

4.8.2 OVERVIEW OF ASSEMBLER CONTROLS

The following tables provide an overview of all assembler controls. For a detailed description, see section 3.3.4, *Detailed Description of Assembler Controls*, in Chapter *Assembly Language* of the *Reference Manual*.

Overview of assembler listing controls

Function	Description
\$LIST ON/OFF	Generation of assembly list file temporary ON/OFF
\$LIST "flags"	Exclude / include lines in assembly list file
\$PAGE	Generate formfeed in assembly list file
\$PAGE settings	Define page layout for assembly list file
\$PRCTL	Send control string to printer
\$STITLE	Set program subtitle in header of assembly list file
\$TITLE	Set program title in header of assembly list file

Overview of miscellaneous assembler controls

Function	Description
\$CASE ON/OFF	Case sensitive user names ON/OFF
\$DEBUG ON/OFF	Generation of symbolic debug ON/OFF
\$DEBUG "flags"	Generation of symbolic debug ON/OFF
\$FPU	Allow single precision floating-point instructions
\$HW_ONLY	Prevent substitution of assembly instructions by smaller or faster instructions
\$IDENT LOCAL/GLOBAL	Assembler treats labels by default as local or global
\$MMU	Allow memory management instructions
\$OBJECT	Alternative name for the generated object file
\$TCdefect ON/OFF	Enable/disable assembler check for specified functional problem
\$TC2	Allow TriCore 2 instructions
\$WARNING OFF [num]	Suppress all or some warnings

4.9 WORKING WITH SECTIONS

Sections are absolute or relocatable blocks of contiguous memory that can contain code or data. Some sections contain code or data that your program declared and uses directly, while other sections are created by the compiler or linker and contain debug information or code or data to initialize your application. These sections can be named in such a way that different modules can implement different parts of these sections. These sections are located in memory by the linker (using the linker script language, LSL) so that concerns about memory placement are postponed until after the assembly process.

All instructions and directives which generate data or code must be within an active section. The assembler emits a warning if code or data starts without a section definition and activation. The compiler automatically generates sections. If you program in assembly you have to define sections yourself.



For more information about locating sections see section 7.7.7 *The Section Layout Definition: Locating Sections* in chapter *Using the Linker*.

Section definition

Sections are defined with the `.SDECL` directive and have a name. A section may have attributes to instruct the linker to place it on a predefined starting address, or that it may be overlaid with another section.

```
.SDECL "name", type [, attribute ]... [AT address]
```



See the `.SDECL` directive in section 3.3.2, *Detailed Description of Assembler Directives*, in chapter *Assembly Language* of the *Reference Manual*, for a complete description of all possible attributes.

Section activation

Sections are defined once and are activated with the `.SECT` directive.

```
.SECT "name"
```

The linker will check between different modules and emits an error message if the section attributes do not match. The linker will also concatenate all matching section definitions into one section. So, all "code" sections generated by the compiler will be linked into one big "code" chunk which will be located in one piece. By using this naming scheme it is possible to collect all pieces of code or data belonging together into one bigger section during the linking phase. A `.SECT` directive referring to an earlier defined section is called a *continuation*. Only the name can be specified.

Example 1

```
.SDECL ".text.hello.main",CODE  
.SECT ".text.hello.main"
```

Defines and activates a relocatable section in CODE memory. Other parts of this section, with the same name, may be defined in the same module or any other module. Other modules should use the same `.SDECL` statement. When necessary, it is possible to give the section an absolute starting address with the locator description file.

Example 2

```
.SDECL ".CONST", CODE AT 0x1000  
.SECT ".CONST"
```

Defines and activates an absolute section named `.CONST` starting on address 0x1000.

Example 3

```
.SDECL ".fardata", DATA, CLEAR  
.SECT ".fardata"
```

Defines a relocatable named section in DATA memory. The CLEAR attribute instructs the linker to clear the memory located to this section. When this section is used in another module it must be defined identically. Continuations of this section in the same module are as follows:

```
.SECT ".fardata"
```

4.10 MACRO OPERATIONS

Macros provide a shorthand method for inserting a repeated pattern of code or group of instructions. You can define the pattern as a macro, and then call the macro at the points in the program where the pattern would repeat.

Some patterns contain variable entries which change for each repetition of the pattern. Others are subject to conditional assembly.

When a macro is called, the assembler executes the macro and replaces the call by the resulting in-line source statements. 'In-line' means that all replacements act as if they are one the same line as the macro call. The generated statements may contain substitutable arguments. The statements produced by a macro can be any processor instruction, almost any assembler directive, or any previously-defined macro. Source statements resulting from a macro call are subject to the same conditions and restrictions as any other statements.

Macros can be *nested*. The assembler processes nested macros when the outer macro is expanded.

4.10.1 DEFINING A MACRO

The first step in using a macro is to define it in the source file. The definition of a macro consists of three parts:

- *Header*, which assigns a name to the macro and defines the arguments.
- *Body*, which contains the code or instructions to be inserted when the macro is called.
- *Terminator*, which indicates the end of the macro definition (.ENDM directive).

A macro definition takes the following form:

```
Header:      macro_name .MACRO [arg[,arg...]] [; comment]
            .
Body:              source statements
            .
Terminator:      .ENDM
```

If the macro name is the same as an existing assembler directive or mnemonic opcode, the assembler replaces the directive or mnemonic opcode with the macro and issues a warning.

The arguments are symbolic names that the macro preprocessor replaces with the literal arguments when the macro is expanded (called). Each argument must follow the same rules as global symbol names. Argument names cannot start with a percent sign (%).

Example

The macro definition:

```
CONSTD .MACRO  reg,value                ;header
      mov.u    reg,#lo(value)           ;body
      addih   reg,reg,#hi(value)
      .ENDM                               ;terminator
```

The macro call:

```
.SDECL  "data",DATA
.SECT   "data"

CONSTD  d4,0x12345678

.END
```

The macro expands as follows:

```
mov.u   d4,#lo(0x12345678)
addih   d4,d4,#hi(0x12345678)
```

4.10.2 CALLING A MACRO

To invoke a macro, construct a source statement with the following format:

```
[label] macro_name [arg[,arg...]]           [;comment]
```

where:

<i>label</i>	An optional label that corresponds to the value of the location counter at the start of the macro expansion.
<i>macro_name</i>	The name of the macro. This must be in the operation field.
<i>arg</i>	One or more optional, substitutable arguments. Multiple arguments must be separated by commas.
<i>comment</i>	An optional comment.

The following applies to macro arguments:

- Each argument must correspond one-to-one with the formal arguments of the macro definition. If the macro call does not contain the same number of arguments as the macro definition, the assembler issues a warning.
- If an argument has an embedded comma or space, you must surround the argument by single quotes (').
- You can declare a macro call argument as NULL in three ways:
 - enter delimiting commas in succession with no intervening spaces

```
macroname ARG1,,ARG3 ; the second argument
                    ; is a NULL argument
```
 - terminate the argument list with a comma, the arguments that normally would follow, are now considered NULL

```
macroname ARG1,      ; the second and all following
                    ; arguments are NULL
```
 - declare the argument as a NULL string
- No character is substituted in the generated statements that reference a NULL argument.

4.10.3 USING OPERATORS FOR MACRO ARGUMENTS

The assembler recognizes certain text operators within macro definitions which allow text substitution of arguments during macro expansion. You can use these operators for text concatenation, numeric conversion, and string handling.

Operator	Name	Description
\	Macro argument concatenation	Concatenates a macro argument with adjacent alphanumeric characters.
?	Return decimal value of symbol	Substitutes the <i>?symbol</i> sequence with a character string that represents the decimal value of the symbol.
%	Return hex value of symbol	Substitutes the <i>%symbol</i> sequence with a character string that represents the hexadecimal value of the symbol.
"	Macro string delimiter	Allows the use of macro arguments as literal strings.
^	Macro local label override	Causes local labels in its term to be evaluated at normal scope rather than at macro scope.

**Argument Concatenation Operator - **

Consider the following macro definition:

```

SWAP_MEM .MACRO REG1,REG2           ;swap memory contents
    LD.W  D0,[A\REG1]              ;use D0 as temp
    LD.W  D1,[A\REG2]              ;use D1 as temp
    ST.W  [A\REG1],D1
    ST.W  [A\REG2],D0
    .ENDM

```

The macro is called as follows:

```

SWAP_MEM 0,1

```

The macro expands as follows:

```

LD.W  D0,[A0]
LD.W  D1,[A1]
ST.W  [A0],D1
ST.W  [A1],D0

```

The macro preprocessor substitutes the character '0' for the argument REG1, and the character '1' for the argument REG2. The concatenation operator (\) indicates to the macro preprocessor that the substitution characters for the arguments are to be concatenated with the character 'A'.

Without the '\ ' operator the macro would expand as:

```
LD.W  D0, [AREG1]
LD.W  D1, [AREG2]
ST.W  [AREG1], D1
ST.W  [AREG2], D0
```

which results in an assembler error.

Decimal value Operator - ?

Instead of substituting the formal arguments with the actual macro call arguments, you can also use the *value* of the macro call arguments.

Consider the following source code that calls the macro SWAP_SYM after the argument AREG has been set to 0 and BREG has been set to 1.

```
AREG .SET      0
BREG .SET      1
SWAP_SYM  AREG, BREG
```

If you want to replace the arguments with the *value* of AREG and BREG rather than with the literal strings 'AREG' and 'BREG', you can use the ? operator and modify the macro as follows:

```
SWAP_SYM  .MACRO  REG1, REG2           ;swap memory contents
LD.W  D0, _lab\?REG1                 ;use D0 as temp
LD.W  D1, _lab\?REG2                 ;use D1 as temp
ST.W  _lab\?REG1, D1
ST.W  _lab\?REG2, D0
      .ENDM
```

The macro first expands as follows:

```
LD.W  D0, _lab\?AREG
LD.W  D1, _lab\?BREG
ST.W  _lab\?AREG, D1
ST.W  _lab\?BREG, D0
```

Then ?AREG is replaced by '0' and ?BREG is replaced by '1':

```
LD.W  D0, _lab\1
LD.W  D1, _lab\2
ST.W  _lab\1, D1
ST.W  _lab\2, D0
```

Because of the concatenation operator '\\' the strings are concatenated:

```
LD.W  D0, _lab1
LD.W  D1, _lab2
ST.W  _lab1, D1
ST.W  _lab2, D0
```

Hex Value Operator - %

The percent sign (%) is similar to the standard decimal value operator (?) except that it returns the hexadecimal value of a symbol.

Consider the following macro definition:

```
GEN_LAB  .MACRO  LAB, VAL, STMT
LAB\%VAL STMT
        .ENDM
```

A symbol with the name NUM is set to 10 and the macro is called with NUM as argument:

```
NUM .SET      10
    GEN_LAB   HEX, NUM, NOP
```

The macro expands as follows:

```
HEXA NOP
```

The %VAL argument is replaced by the character 'A' which represents the hexadecimal value 10 of the argument VAL.

Argument String Operator - "

To generate a literal string, enclosed by single quotes ('), you must use the argument string operator (") in the macro definition.

Consider the following macro definition:

```
STR_MAC  .MACRO  STRING
        .BYTE  "STRING"
        .ENDM
```

The macro is called as follows:

```
STR_MAC ABCD
```

The macro expands as follows:

```
.BYTE 'ABCD'
```

Within double quotes `.DEFINE` directive definitions can be expanded. Take care when using constructions with quotes and double quotes to avoid inappropriate expansions. Since a `.DEFINE` expansion occurs before a macro substitution, all `DEFINE` symbols are replaced first within a macro argument string:

```
.DEFINE LONG 'short'
STR_MAC .MACRO STRING
.MESSAGE 'This is a LONG STRING'
.MESSAGE "This is a LONG STRING"
.ENDM
```

If the macro is called as follows:

```
STR_MAC sentence
```

The macro expands as:

```
.MESSAGE 'This is a LONG STRING'
.MESSAGE 'This is a short sentence'
```

Single quotes prevent expansion so the first `.MESSAGE` is not stated as is. In the double quoted `.MESSAGE`, first the define `LONG` is expanded to 'short' and then the argument `STRING` is substituted by 'sentence'.

Macro Local Label Override Operator - ^

If you use labels in macros, the assembler normally generates another unique name for the labels (such as `LAB__M_L0000001`).

The macro `^`-operator prevents name mangling on macro local labels.

Consider the following macro definition:

```
INIT .MACRO ARG, CNT
LD.W D0,1
^LAB:
.BYTE ARG
JNEI D0,#CNT,^LAB
.ENDM
```

The macro is called as follows:

```
INIT 2,4
```

The macro expands as:

```
LD.W D0,1
LAB:
.BYTE 2
JNEI D0,#4,LAB
```

Without the ^ operator, the macro preprocessor would choose another name for LAB because the label already exists. The macro then would expand like:

```
LD.W D0,1
LAB__M_L000001:
.BYTE 2
JNEI D0,#4,LAB__M_L000001
```

4.10.4 USING THE .DUP, .DUPA, .DUPC, .DUPF DIRECTIVES AS MACROS

The .DUP, .DUPA, .DUPC, and .DUPF directives are specialized macro forms to repeat a block of source statements. You can think of them as a simultaneous definition and call of an unnamed macro. The source statements between the .DUP, .DUPA, .DUPC, and .DUPF directives and the .ENDM directive follow the same rules as macro definitions.



For a detailed description of these directives, see section 3.3, *Assembler Directives*, in Chapter *Assembly Language* of the *Reference Manual*.

4.10.5 CONDITIONAL ASSEMBLY: .IF, .ELIF AND .ELSE DIRECTIVES

With the conditional assembly directives you can instruct the macro preprocessor to use a part of the code that matches a certain condition.

You can specify assembly conditions with arguments in the case of macros, or through definition of symbols via the .DEFINE, .SET, and .EQU directives.

The built-in functions of the assembler provide a versatile means of testing many conditions of the assembly environment.

You can use conditional directives also within a macro definition to check at expansion time if arguments fall within a certain range of values. In this way macros become self-checking and can generate error messages to any desired level of detail.

The conditional assembly directive `.IF` has the following form:

```
.IF  expression
.
.
[.ELIF  expression] ;(the .ELIF directive is optional)
.
.
[.ELSE]                ;(the .ELSE directive is optional)
.
.
.ENDIF
```

The *expression* must evaluate to an absolute integer and cannot contain forward references. If *expression* evaluates to zero, the `.IF`-condition is considered FALSE. Any non-zero result of *expression* is considered as TRUE.



For a detailed description of these directives, see section 3.3, *Assembler Directives*, in Chapter *Assembly Language* of the *Reference Manual*.

CHAPTER

5

USING THE COMPILER

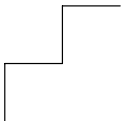

5 | CHAPTER

5.1 INTRODUCTION

EDE uses a *makefile* to build your entire project, from C source till the final ELF/DWARF object file which serves as input for the debugger.

Although in EDE you cannot run the compiler separately from the other tools, this chapter discusses the options that you can specify for the compiler.

On the command line it is possible to call the compiler separately from the other tools. However, it is recommended to use the control program **ctc** for command line invocations of the toolchain (see section 8.2, *Control Program*, in Chapter *Using the Utilities*). With the control program it is possible to call the entire toolchain with only one command line.

The compiler takes the following files for input and output:

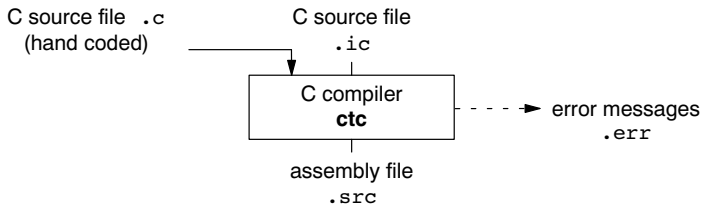

Figure 5-1: C compiler

This chapter first describes the compilation process which consists of a *frontend* and a *backend* part. During compilation the code is optimized in several ways. The various optimizations are described in the second section. Third it is described how to call the compiler and how to use its options. An extensive list of all options and their descriptions is included in the section 5.1, *Compiler Options*, in Chapter 5, *Tool Options*, of the *Reference Manual*. Finally, a few important basic tasks are described.

5.2 COMPILATION PROCESS

During the compilation of a C program, the compiler **ctc** runs through a number of phases that are divided into two groups: *frontend* and *backend*.

The backend part is not called for each C statement, but starts after a complete C module or set of modules has been processed by the frontend (in memory). This allows better optimization.

The compiler requires only one pass over the input file which results in relative fast compilation.

Frontend phases

1. The preprocessor phase:

The preprocessor includes files and substitutes macros by C source. It uses only string manipulations on the C source. The syntax for the preprocessor is independent of the C syntax but is also described in the ISO/IEC 9899:1999(E) standard.

2. The scanner phase:

The scanner converts the preprocessor output to a stream of tokens.

3. The parser phase:

The tokens are fed to a parser for the C grammar. The parser performs a syntactic and semantic analysis of the program, and generates an intermediate representation of the program. This code is called MIL (Medium level Intermediate Language).

4. The frontend optimization phase:

Target processor *independent* optimizations are performed by transforming the intermediate code.

Backend phases

5. Instruction selector phase:

This phase reads the MIL input and translates it into Low level Intermediate Language (LIL). The LIL objects correspond to a TriCore processor instruction, with an opcode, operands and information used within the compiler.

6. Peephole optimizer/instruction scheduler/software pipelining phase:

This phase replaces instruction sequences by equivalent but faster and/or shorter sequences, rearranges instructions and deletes unnecessary instructions.

7. Register allocator phase:

This phase chooses a physical register to use for each virtual register.

8. The backend optimization phase:

Performs target processor *independent* and *dependent* optimizations which operate on the Low level Intermediate Language.

9. The code generation/formatter phase:

This phase reads through the LIL operations to generate assembly language output.

5.3 COMPILER OPTIMIZATIONS

The compiler has a number of optimizations which you can enable or disable. To enable or disable optimizations:

1. From the **Project** menu, select **Project Options...**

The Project Options dialog box appears.

2. Expand the **C Compiler** entry and select **Optimization**.
3. Select an optimization level in the **Optimization level** box.

or:

In the **Optimization level** box, select **Custom optimization** and enable the optimizations you want in the **Custom optimization** box.

If you specify a certain optimization, all code in the module is subject to that optimization. Within the C source file you can overrule the compiler options for optimizations with `#pragma optimize flag` and `#pragma endoptimize`. Nesting is allowed:

```
#pragma optimize e    /* Enable expression
...                  simplification          */
... C source ...
...
#pragma optimize c    /* Enable common expression
...                  elimination. Expression
... C source ...     simplification still enabled */
...
#pragma endoptimize  /* Disable common expression
...                  elimination          */
#pragma endoptimize  /* Disable expression
...                  simplification      */
```

The compiler optimizes the code between the pragma pair as specified.

You can enable or disable the optimizations described below. The command line option for each optimization is given in brackets.



See also option `-O` (`--optimize`) in section 5.1, *Compiler Options*, of Chapter *Tool Options* of the *TriCore Reference Manual*.

Generic optimizations (frontend)

Common subexpression elimination (CSE) *(option -Oc/-OC)*

The compiler detects repeated use of the same (sub-)expression. Such a "common" expression is replaced by a variable that is initialized with the value of the expression to avoid recomputation. This method is called *common subexpression elimination* (CSE).

Expression simplification *(option -Oe/-OE)*

Multiplication by 0 or 1 and additions or subtractions of 0 are removed. Such useless expressions may be introduced by macros or by the compiler itself (for example, array subscription).

Constant propagation *(option -Op/-OP)*

A variable with a known constant value is replaced by that value.

Function Inlining (option **-Oi/-OI**)

Small functions that are not too often called, are inlined. This reduces execution time at the cost of code size.

Control flow simplification (option **-Of/-OF**)

A number of techniques to simplify the flow of the program by removing unnecessary code and reducing the number of jumps. For example:

Switch optimization:

A number of optimizations of a switch statement are performed, such as removing redundant case labels or even removing an entire switch.

Jump chaining:

A (conditional) jump to a label which is immediately followed by an unconditional jump may be replaced by a jump to the destination label of the second jump. This optimization speeds up execution.

Conditional jump reversal:

A conditional jump over an unconditional jump is transformed into one conditional jump with the jump condition reversed. This reduces both the code size and the execution time.

Dead code elimination:

Code that is never reached, is removed. The compiler generates a warning messages because this may indicate a coding error.

Subscript strength reduction (option **-Os/-OS**)

An array of pointer subscripted with a loop iterator variable (or a simple linear function of the iterator variable), is replaced by the dereference of a pointer that is updated whenever the iterator is updated.

Loop transformations (option **-Ol/-OL**)

Temporarily transform a loop with the entry point at the bottom, to a loop with the entry point at the top. This enables *constant propagation* in the initial loop test and code motion of loop invariant code by the *CSE* optimization.

Forward store (option **-Oo/-OO**)

A temporary variable is used to cache multiple assignments (stores) to the same non-automatic variable.

Core specific optimizations (backend)

Coalescer

(option **-Oa/-OA**)

The coalescer seeks for possibilities to reduce the number of moves (MOV instruction) by smart use of registers. This optimizes both speed as code size.

Peephole optimizations

(option **-Oy/-OY**)

The generated assembly code is improved by replacing instruction sequences by equivalent but faster and/or shorter sequences, or by deleting unnecessary instructions.

Instruction Scheduler

(option **-Ok/-OK**)

Instructions are rearranged with the following purposes:

- Pairing a L/S instruction with a data arithmetic instruction in order to fill both pipelines as much as possible.
- Avoiding structural hazards by inserting another non-related instruction.

IFconversion

(option **-Ov/-OV**)

IF – ELSE constructions are transformed into predicated instructions. This avoids unnecessary jumps while the predicated instructions are optimized by the *pipeline scheduler* and the *predicate optimization*.

Software pipelining

(option **-Ow/-OW**)

A number of techniques to optimize loops. For example, within a loop the most efficient order of instructions is chosen by the *pipeline scheduler* and it is examined what instructions can be executed parallel.

Use of SIMD instructions

(option **-Om/-OM**)

The iteration counts of loops are reduced where possible by taking advantage of the TriCore SIMD instructions. This optimizes speed, but may cause a slight increase in code size.

Generic assembly optimizations

(option **-Og/-OG**)

A set of target independent optimizations that increase speed and decrease code size.

5.3.1 OPTIMIZE FOR SIZE OR SPEED

You can tell the compiler to focus on execution speed or code size during optimizations. You can do this by specifying a size/speed trade-off level from 0 (speed) to 4 (size). This trade-off does not turn optimization phases on or off. Instead, its level is a weight factor that is used in the different optimization phases to influence the heuristics. The higher the level, the more the compiler focuses on code size optimization.

To specify the size/speed trade-off optimization level:

1. From the **Project** menu, select **Project Options...**

The Project Options dialog box appears.

2. Expand the **C Compiler** entry and select **Optimization**.
3. Select a **Size/speed trade-off** level.



See also option **-t** (**--tradeoff**) in section 5.1, *Compiler Options*, in Chapter *Tool Options* of the *TriCore Reference Manual*.

5.4 CALLING THE COMPILER

EDE uses a *makefile* to build your entire project. This means that you cannot run the compiler only. If you compile a single C source file from within EDE, the file is also automatically assembled. However, you can set options specific for the compiler. After you have build your project, the output files of the compilation step are available in your project directory.

To compile your program, click either one of the following buttons:



Compiles and assembles the currently selected file. This results in a relocatable object file (`.o`).



Builds your entire project but looks whether there are already files available that are needed in the building process. If so, these files will not be generated again, which saves time.



Builds your entire project unconditionally. All steps necessary to obtain the final `.elf` file are performed.

To only check for syntax errors, click the following button:



Checks the currently selected file for syntax errors, but does not generate code.

Select a predefined target processor

1. From the **Project** menu, select **Project Options...**

The Project Options dialog appears.

2. Expand the **Processor** entry and select **Processor Definition**.
3. In the **Target processor** list select the target processor.
4. Click **OK** to accept the new project settings.

The compiler includes the register file `regcpu.sfr`.

Based on the target processor, the compiler includes a *special function register file* `regcpu.sfr`. This is an include file written in C syntax which is shared by the compiler, assembler and debugger. Once the compiler reads an SFR file you can reference the special function registers (SFR) and bits within an SFR using symbols defined in the SFR file.

Define a user defined target processor

1. From the **Project** menu, select **Project Options...**

The Project Options dialog box appears.

2. Expand the **Processor** entry and select **Processor Definition**.
3. In the **Target processor** list, select one of the **(user defined ...)** entries.
4. Specify (part of) the name of the user defined SFR files.

The compiler uses this name to include the register file `regname.sfr`.

5. (Optional) Specify if your user defined target processor has an FPU (Floating-Point Unit) and/or an MMU (Memory Management Unit).
6. Click **OK** to accept the new project settings.

Processor options affect the invocation of all tools in the toolchain. In EDE you only need to set them once. The corresponding options for the compiler are listed in table 5-1.

To specify the search path and include directories

1. From the **Project** menu, select **Directories...**

The Directories dialog box appears.

2. Fill in the directory path settings and click **OK**.

To access the compiler options

1. From the **Project** menu, select **Project Options...**

The Project Options dialog box appears.

2. Expand the **C Compiler** entry, fill in the various pages and click **OK** to accept the compiler options.

*The compiler command line equivalences of your EDE selections are shown simultaneously in the **Options string** box.*

The following **processor** options are available:

EDE options	Command line
Processor definition	
Target processor	<code>-Ccpu</code>
User defined TriCore 2	<code>--is-tricore2</code>
FPU present (use hardware floating point instructions)	<code>--fpu-present</code>
Bypasses	
CPU functional problem bypasses	<code>--silicon-bug= bug</code>
Startup	
Automatically add cstart.asm to your project	<i>EDE only</i>
Bus Configuration	
Initialize bus configuration registers in startup code	<i>EDE only</i>

Table 5-1: Processor options

The following project directories can be defined:

EDE options	Command line
Directories	
Executable files path	<code>\$PATH environment</code>
Include files path	<code>-ldir</code>
Library files path	<i>linker option</i> <code>-Ldir</code>

Table 5-2: Project directories

The following **compiler** options are available:

EDE options	Command line
Preprocessing	
Store the C compiler preprocess output (<i>file.pre</i>)	<code>-Eflag</code>
Keep comments	<code>-Ec</code>
Strip #line source position info	<code>-Ep</code>
Automatic inclusion of '.sfr' file	<code>--no-tasking-sfr</code>
Define user macros	<code>-Dmacro[=def]</code>
Include this file before source	<code>-Hfile</code>

EDE options	Command line
Language	
ISO C standard 90 or 99 (default: 99)	-c{90 99}
Treat 'char' variables as unsigned instead of signed	-u
Use 32-bits integers for enumeration	--integer- enumeration
Single precision floating-point: treat 'double' as 'float'	-F
Call functions indirect	--indirect
Language extensions	-Aflag
Allow C++ style comments in C source	-Ap
Allow relaxed const check for string literals	-Ax
Debug Information	
Generate symbolic debug information	-g
Optimization	
No optimization	-O0
Debug purpose optimization	-O1
Release purpose optimization (default)	-O2
Aggressive optimization	-O3
Custom optimization	-Oflag
Size/speed trade-off (default: speed (0))	-t{0 1 2 3 4}
All addresses available for CSE evaluation	--cse-all-addresses
Maximum size increment inlining	--inline-max-incr
Maximum size for functions to always inline	--inline-max-size
Allocation	
Default __near allocation for objects below treshold	-Nthreshold
Default __a0 allocation for objects below treshold	-Zthreshold
Default __a1 allocation for objects below treshold	-Ythreshold
Warnings	
Report all warnings	omit option -w
Suppress all warnings	-w
Suppress specific warnings	-wnum[,num]...
Treat warnings as errors	--warnings-as- errors
MISRA C	
Disable MISRA C code checking	omit option --misrac
Supported MISRA C required rules	--misrac={all number
Custom MISRA C configuration	[-number],... }

EDE options	Command line
Use external MISRA C configuration file	<i>no option</i>
Produce MISRA C report file	<i>linker option</i> --misra-c-report
Miscellaneous	
Merge C source code with assembly in output file (.src)	-s
Additional command line options	<i>options</i>
Additional command line options	<i>options</i>

Table 5-3: Compiler options

The following options are only available on the command line:

Description	Command line
Display invocation syntax	-?
Specify alignment (same as #pragma align <i>n</i>)	--align=<i>n</i>
Make all addresses available for CSE	--cse-all-addresses
Show description of diagnostic(s)	--diag=[<i>fmt</i>:]{all <i>nr</i>,...}
Redirect diagnostic messages to a file	--error-file=[<i>file</i>]
Read options from file	-f <i>file</i>
Maximum size increment inlining (in %) (default: 25)	--inline-max-incr=<i>value</i>
Maximum size for function to always inline (default: 10)	--inline-max-size=<i>value</i>
Always use 32-bit integers for enumeration	--integer-enumeration
Keep output file after errors	-k
Send output to standard output	-n
Specify name of output file	-o <i>file</i>
Display version header only	-V

Table 5-4: Compiler options only available on the command line



The invocation syntax on the command line is:

```
ctc [option]... [file]
```

The input file must be a C source file (`.c` or `.ic`).

```
ctc test.c
```

This compiles the file `test.c` and generates the file `test.src` which serves as input for the assembler.



For a complete overview of all options with extensive description, see section 5.1, *Compiler Options*, of Chapter *Tool Options* of the *TriCore Reference Manual*.

5.5 HOW THE COMPILER SEARCHES INCLUDE FILES

When you use include files, you can specify their location in several ways. The compiler searches the specified locations in the following order:

1. If the `#include` statement contains a pathname, the compiler looks for this file. If no path is specified, the compiler looks in the same directory as the source file. This is only possible for include files that are enclosed in `""`.



This first step is not done for include files enclosed in `<>`.

2. When the compiler did not find the include file, it looks in the directories that are specified in the **Directories** dialog (`-I` option).
3. When the compiler did not find the include file (because it is not in the specified include directory or because no directory is specified), it looks which paths were set during installation. You can still change these paths.



See section 1.3.1, *Configuring the Embedded Development Environment* and environment variable `CTCINC` in section 1.3.2, *Configuring the Command Line Environment*, in Chapter *Software Installation*.

4. When the compiler still did not find the include file, it finally tries the default `include` directory relative to the installation directory.

5.6 COMPILING FOR DEBUGGING

Compiling your files is the first step to get your application ready to run on a target. However, during development of your application you first may want to debug your application.

To create an object file that can be used for debugging, you must instruct the compiler to include *symbolic debug information* in the source file.

1. From the **Project** menu, select **Project Options...**

The Project Options dialog box appears.

2. Expand the **C Compiler** entry and select **Debug Information**.
3. Enable the option **Generate symbolic debug information**.
4. Click **OK** to accept the new project settings.



```
ctc -g
```

Due to different compiler optimizations, it might be possible that certain debug information is optimized away. Therefore, it is best to specify **No optimization (-O0)** when you want to debug your application.

1. From the **Project** menu, select **Project Options...**

The Project Options dialog box appears.

2. Expand the **C Compiler** entry and select **Optimization**.
3. In the **Optimization level** box, select **No optimization**.

5.7 C CODE CHECKING: MISRA C

The C programming language is a standard for high level language programming in embedded systems, yet it is considered somewhat unsuitable for programming safety-related applications. Through enhanced code checking and strict enforcement of best practice programming rules, TASKING MISRA C code checking helps you to produce more robust code.

MISRA C specifies a subset of the C programming language which is intended to be suitable for embedded automotive systems. It consists of a set of 127 rules, defined in the document "Guidelines for the Use of the C Language in Vehicle Based Software" published by "Motor Industry Research Association" (MISRA).



For a complete overview of all MISRA C rules, see Chapter 10, *MISRA C Rules*, in the *Reference Manual*.

The MISRA C implementation in the compiler supports 117 of the 127 rules. Some MISRA C rules address documentation, run-time behavior, or other issues that cannot be checked by static source code inspection. Therefore, the following rules are not implemented: 2, 4, 6, 15, 41, 116, 117. In addition, the rules 23, 25 and 27 are not implemented in the compiler, because they cannot be checked without an application-wide overview.

During compilation of the code, violations of the enabled MISRA C rules are indicated with error messages and the build process is halted.



Note that not all MISRA C violations will be reported when other errors are detected in the input source. For instance, when there is a syntax error, all semantic checks will be skipped, including some of the MISRA C checks. Also note that some checks cannot be performed when the optimizations are switched off.

To ensure compliance to the MISRA C rules throughout the entire project, the TASKING TriCore linker can generate a MISRA C Quality Assurance report. This report lists the various modules in the project with the respective MISRA C settings at the time of compilation. You can use this in your company's quality assurance system to provide proof that company rules for best practice programming have been applied in the particular project.

Apply MISRA C code checking to your application

1. From the **Project** menu, select **Project Options...**

The Project Options dialog box appears.

2. Expand the **C Compiler** entry and select **MISRA C**.
3. Select a MISRA C configuration. Select a predefined configuration for conformance with the required rules in the MISRA C guidelines.
4. (Optional) In the **MISRA C Rules** entry, specify the individual rules.



ctc **--misrac**={**all** | *number* [*-number*],...}



See compiler option **--misrac** in section 5.1, *Compiler Options* in Chapter *Tool Options* of the *TriCore Reference Manual*.

See linker option **--misra-c-report** in section 5.3, *Linker Options* in Chapter *Tool Options* of the *TriCore Reference Manual*.

5.8 C COMPILER ERROR MESSAGES

The **csc** compiler reports the following types of error messages:

F Fatal errors

After a fatal error the compiler immediately aborts compilation.

E Errors

Errors are reported, but the compiler continues compilation. No output files are produced unless you have set the compiler option

--keep-output-files (the resulting output file may be incomplete).

W Warnings

Warning messages do not result into an erroneous assembly output file.

They are meant to draw your attention to assumptions of the compiler for a situation which may not be correct. You can control warnings in the **C Compiler | Warnings** page of the **Project | Project Options...** menu (compiler option **-w**).

I Information

Information messages are always preceded by an error message.

Information messages give extra information about the error.

S System errors

System errors occur when internal consistency checks fail and should never occur. When you still receive the system error message

```
S9##: internal consistency check failed - please report
```

please report the error number and as many details as possible about the context in which the error occurred. The following helps you to prepare an e-mail using EDE:

1. From the **Help** menu, select **Technical Support -> Prepare Email...**

The Prepare Email form appears.

2. Fill out the the form. State the error number and attach relevant files.

3. Click the **Copy to Email client** button to open your email application.

A prepared e-mail opens in your e-mail application.

4. Finish the e-mail and send it.

Display detailed information on diagnostics

1. In the **Help** menu, enable the option **Show Help on Tool Errors**.
2. In the **Build** tab of the **Output** window, double-click on an error or warning message.

A description of the selected message appears.



```
ctc --diag=[format:]{all | number,...}
```



See compiler option **--diag** in section 5.1, *Compiler Options* in Chapter *Tool Options* of the *TriCore Reference Manual*.

CHAPTER

9

USING THE ASSEMBLER



6 | CHAPTER

6.1 INTRODUCTION

The assembler converts hand-written or compiler-generated assembly language programs into machine language, using the Executable and Linking Format (ELF) for object files.

The assembler takes the following files for input and output:

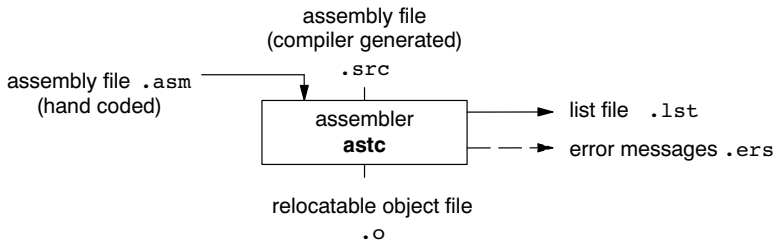

Figure 6-1: Assembler

This chapter first describes the assembly process. The various assembler optimizations are described in the second section. Third it is described how to call the assembler and how to use its options. An extensive list of all options and their descriptions is included in the *Reference Manual*. Finally, a few important basic tasks are described.

6.2 ASSEMBLY PROCESS

The assembler generates relocatable output files with the extension `.o`. These files serve as input for the linker.

Phases of the assembly process

1. Parsing of the source file: preprocessing of assembler directives and checking of the syntax of instructions
2. Optimization (instruction size and generic instructions)
3. Generation of the relocatable object file and optionally a list file

The assembler integrates file inclusion and macro facilities. See section 4.10, *Macro Operations*, in Chapter *TriCore Assembly Language* for more information.

6.3 ASSEMBLER OPTIMIZATIONS

The **astc** assembler performs various optimizations to reduce the size of the assembled applications. There are two options available to influence the degree of optimization. To enable or disable optimizations:

1. From the **Project** menu, select **Project Options...**

The Project Options dialog box appears.

2. Expand the **Assembler** entry and select **Optimization**.

You can enable or disable the optimizations described below. The command line option for each optimization is given in brackets.



See also option **-O** (**--optimize**) in section 5.2, *Assembler Options*, in Chapter *Tool Options* of the *TriCore Reference Manual*.

Allow generic instructions

(option **-Og/-OG**)

When this option is enabled, you can use generic instructions in your assembly source. The assembler tries to replace the generic instructions by faster or smaller instructions. For example, the instruction `jeq d0,#0,label1` is replaced by `jz d0,label1`.

By default this option is enabled. Because shorter instructions may influence the number of cycles, you may want to disable this option when you have written timed code. In that case the assembler encodes all instructions as they are.

Optimize instruction size

(option **-Os/-OS**)

When this option is enabled, the assembler tries to find the shortest possible operand encoding for instructions. By default this option is enabled.

6.4 CALLING THE ASSEMBLER

EDE uses a *makefile* to build your entire project. You can set options specific for the assembler. After you have build your project, the output files of the assembling step are available in your project directory.

To assemble your program, click either one of the following buttons:



Assembles the currently selected assembly file (`.asm` or `.src`). This results in a relocatable object file (`.o`).



Builds your entire project but looks whether there are already files available that are needed in the building process. If so, these files will not be generated again, which saves time.



Builds your entire project unconditionally. All steps necessary to obtain the final `.elf` file are performed.

To only check for syntax errors, click the following button:



Checks the currently selected assembly file for syntax errors, but does not generate code.

Select a target processor (core)

Because the toolchain supports several processor cores, you need to choose a processor type first.

To access the TriCore processor options:

1. From the **Project** menu, select **Project Options...**

The Project Options dialog box appears.

2. Expand the **Processor** entry, fill in the **Processor Definition** page and optionally the **Startup** page and click **OK** to accept the processor options.

Processor options affect the invocation of all tools in the toolchain. In EDE you only need to set them once. The corresponding options for the assembler are listed in table 6-1.

Based on the target processor, the assembler includes a *special function register file* `regcpu.def`. Once the assembler reads an SFR file you can reference the special function registers (SFR) and bits within an SFR using symbols defined in the SFR file.

To access the assembler options

1. From the **Project** menu, select **Project Options...**

The Project Options dialog box appears.

2. Expand the **Assembler** entry, fill in the various pages and click **OK** to accept the compiler options.

*The assembler command line equivalences of your EDE selections are shown simultaneously in the **Options string** box.*

The following processor options are available:

EDE options	Command line
Target	
Target processor User defined TriCore 2	-Ccpu --is-tricore2
FPU present	--fpu-present
MMU present	--mmu-present
Bypasses	
CPU functional problem bypasses	--silicon-bug= bug
Startup	
Automatically add cstart.asm to your project	<i>EDE only</i>
Bus Configuration	
Initialize bus configuration registers in startup code	<i>EDE only</i>

Table 6-1: Processor options

The following assembler options are available:

EDE options	Command line
Preprocessing	
Select TASKING preprocessor or no preprocessor	-m{t n}
Define user <i>macro</i>	-Dmacro[=def]
Include this <i>file</i> before source	-Hfile
List File	
Generate list file	-l
Display section information	-tl

EDE options	Command line
List file format	<code>-Lflags</code>
Debug Information	
No debug information	<code>-gAHLs</code>
Automatic HLL or assembly level debug information	<code>-gs</code>
Custom debug information	<code>-gflag</code>
Optimization	
Generic instructions	<code>-Og/-OG</code> (= on/off)
Instruction size	<code>-Os/-OS</code>
Warnings	
Report all warnings	<code>omit option -w</code>
Suppress all warnings	<code>-w</code>
Suppress specific warnings	<code>-wnum[,num]...</code>
Treat warnings as errors	<code>--warnings-as-errors</code>
Miscellaneous	
Assemble case sensitive	<code>-c</code>
Labels are by default:	
local (default)	<code>-il</code>
global	<code>-ig</code>
Additional options	<code>options</code>

Table 6-2: Assembler options

The following options are available on the command line, and you can set them in EDE through the **Additional options** field in the **Miscellaneous** page:

Description	Command line
Display invocation syntax	<code>-?</code>
Emit local symbols	<code>--emit-locals</code>
Redirect diagnostic messages to a file	<code>--error-file[=file]</code>
Read options from file	<code>-f file</code>
Keep output file after errors	<code>-k</code>
Specify name of output file	<code>-o file</code>
Display version header only	<code>-V</code>

Table 6-3: Assembler command line options



The invocation syntax on the command line is:

```
astc [option]... [file]
```

The input file must be an assembly source file (**.asm** or **.src**).

```
astc test.asm
```

This assembles the file **test.asm** for and generates the file **test.o** which serves as input for the linker.



For a complete overview of all options with extensive description, see section 5.2, *Assembler Options*, of Chapter *Tool Options* of the *TriCore Reference Manual*.

6.5 HOW THE ASSEMBLER SEARCHES INCLUDE FILES

When you use include files, you can specify their location in several ways. The assembler searches the specified locations in the following order:

1. The absolute pathname, if specified in the **.INCLUDE** directive. Or, if no path or a relative path is specified, the same directory as the source file.
2. The directories that are specified in the **Project | Directories** dialog (**-I** option).
3. The paths which were set during installation. You can still change these paths.



See section 1.3.1, *Configuring the Embedded Development Environment* and environment variable **ASTCINC** in section 1.3.2, *Configuring the Command Line Environment*, in Chapter *Software Installation*.

4. The default **include** directory relative to the installation directory.

6.6 GENERATING A LIST FILE

The list file is an additional output file that contains information about the generated code. You can also customize the amount and form of information.

If the assembler generates errors or warnings, these are reported in the list file just below the source line that caused the error or warning.

To generate a list file

1. From the **Project** menu, select **Project Options...**

The Project Options dialog appears.

2. Expand the **Assembler** entry and select **List File**.
3. Enable the option **Generate list file**.
4. (Optional) Enable the options you want to include in the list file.

EDE generates a list file for each source file in your project. A list file gets the same basename as the source file but with extension .lst.

Example on the command line

The following command generates the list file `test.lst`.

```
astc -l test.src
```



See section 6.1, *Assembler List File Format*, in Chapter *List File Formats* of the *Reference Manual* for an explanation of the format of the list file.

6.7 ASSEMBLER ERROR MESSAGES

The assembler produces error messages of the following types:

F Fatal errors

After a fatal error the assembler immediately aborts the assembling process.

E Errors

Errors are reported, but the assembler continues assembling. No output files are produced unless you have set the assembler option **--keep-output-files** (the resulting output file may be incomplete).

W Warnings

Warning messages do not result into an erroneous assembly output file. They are meant to draw your attention to assumptions of the assembler for a situation which may not be correct. You can control warnings in the **Assembler | Warnings** page of the **Project | Project Options...** menu (assembler option **-w**).

Display detailed information on diagnostics

1. In the **Help** menu, enable the option **Show Help on Tool Errors**.
2. In the **Build** tab of the **Output** window, double-click on an error or warning message.

A description of the selected message appears.



astc **--diag**=[*format* :] { **all** | *number* , ... }



See assembler option **--diag** in section 5.2, *Assembler Options* in Chapter *Tool Options* of the *TriCore Reference Manual*.

CHAPTER

7

USING THE LINKER



7 | CHAPTER

7.1 INTRODUCTION

The linker **ltc** is a combined linker/locator. The linker phase combines relocatable object files (`.o` files, generated by the assembler), and libraries into a single *relocatable linker object file* (`.out`). The locator phase assigns absolute addresses to the linker object file and creates an absolute object file which you can load into a target processor. From this point the term *linker* is used for the combined linker/locator.

The linker takes the following files for input and output:

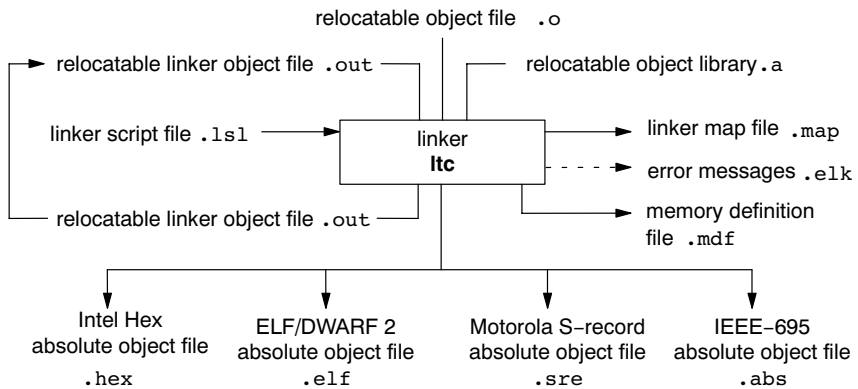

Figure 7-1: *ltc* Linker

This chapter first describes the linking process. Then it describes how to call the linker and how to use its options. An extensive list of all options and their descriptions is included in section 5.3, *Linker Options*, of the *Reference Manual*.

To gain even more control over the link process, you can write a script for the linker. This chapter shortly describes the purpose and basic principles of the *Linker Script Language* (LSL) on the basis of an example. A complete description of the LSL is included in Chapter 8, *Linker Script Language*, of the *Reference Manual*.

The end of the chapter describes how to generate a map file and contains an overview of the different types of messages of the linker.

7.2 LINKING PROCESS

The linker combines and transforms relocatable object files (.o) into a single absolute object file. This process consists of two phases: the linking phase and the locating phase.

In the first phase the linker combines the supplied relocatable object files and libraries into a single relocatable object file. In the second phase, the linker assigns absolute addresses to the object file so it can actually be loaded into a target.

Glossary of terms

Term	Definition
Absolute object file	Object code in which addresses have fixed absolute values, ready to load into a target.
Address	A specification of a location in an address space.
Address space	The set of possible addresses. A core can support multiple spaces, for example in a Harvard architecture the addresses that identify the location of an instruction refer to code space, whereas addresses that identify the location of a data object refer to a data space.
Architecture	A description of the characteristics of a core that are of interest for the linker. This encompasses the logical address space(s) and the internal bus structure. Given this information the linker can convert logical addresses into physical addresses.
Copy table	A section created by the linker. This section contains data that specifies how the startup code initializes the data and BSS sections. For each section the copy table contains the following fields: <ul style="list-style-type: none"> – action: defines whether a section is copied or zeroed – destination: defines the section's address in RAM. – source: defines the sections address in ROM, zero for BSS sections – length: defines the size of the section in MAUs of the destination space
Core	An instance of a core architecture.
Derivative	The design of a processor. A description of one or more cores including internal memory and any number of buses.
Library	Collection of relocatable object files. Usually each object file in a library contains one symbol definition (for example, a function).

Term	Definition
Logical address	An address as encoded in an instruction word, an address generated by a core (CPU).
LSL file	The set of linker script files that are passed to the linker.
MAU	Minimum Addressable Unit. For a given processor the number of bits loaded between an address and the next address. This is not necessarily a byte or a word.
Object code	The binary machine language representation of the C source.
Physical address	An addresses generated by the memory system.
Processor	An instance of a derivative. Usually implemented as a (custom) chip, but can also be implemented in an FPGA, in which case the derivative can be designed by the developer.
Relocatable object file	Object code in which addresses are represented by symbols and thus relocatable.
Relocation	The process of assigning absolute addresses.
Relocation information	Information about how the linker must modify the machine code instructions when it relocates addresses.
Section	A group of instructions and/or data objects that occupy a contiguous range of addresses.
Section attributes	Attributes that define how the section should be linked or located.
Target	The hardware board on which an application is executing. A board contains at least one processor. However, a complex target may contain multiple processors and external memory that may be shared between processors.
Unresolved reference	A reference to a symbol for which the linker did not find a definition yet.

Table 7-1: Glossary of terms

7.2.1 PHASE 1: LINKING

The linker takes one or more relocatable object files and/or libraries as input. A relocatable object file, as generated by the assembler, contains the following information:

- *Header information*: Overall information about the file, such as the code size, name of the source file it was assembled from, and creation date.
- *Object code*: Binary code and data, divided into various named sections. Sections are contiguous chunks of code or data that have to be placed in specific parts of the memory. The program addresses start at zero for each section in the object file.
- *Symbols*: Some symbols are exported – defined within the file for use in other files. Other symbols are imported – used in the file but not defined (external symbols). Generally these symbols are names of routines or names of data objects.
- *Relocation information*: A list of places with symbolic references that the linker has to replace with actual addresses. When in the code an external symbol (a symbol defined in another file or in a library) is referenced, the assembler does not know the symbol's size and address. Instead, the assembler generates a call to a preliminary relocatable address (usually 0000), while stating the symbol name.
- *Debug information*: Other information about the object code that is used by a debugger. The assembler optionally generates this information and can consist of line numbers, C source code, local symbols and descriptions of data structures.

The linker resolves the external references between the supplied relocatable object files and/or libraries and combines the supplied relocatable object files into a single relocatable linker object file.

The linker starts its task by scanning all specified relocatable object files and libraries. If the linker encounters an unresolved symbol, it remembers its name and continues scanning. The symbol may be defined elsewhere in the same file, or in one of the other files or libraries that you specified to the linker. If the symbol is defined in a library, the linker extracts the object file with the symbol definition from the library. This way the linker collects all definitions and references of all of the symbols.

With this information, the linker combines the object code of all relocatable object files. The linker combines sections with the same section name and attributes into single sections, starting each section at address zero. The linker also substitutes (external) symbol references by (relocatable) numerical addresses where possible. At the end of the linking phase, the linker either writes the results to a file (a single relocatable object file) or keeps the results in memory for further processing during the locating phase.

The resulting file of the linking phase is a single relocatable object file (`.out`). If this file contains unresolved references, you can link this file with other relocatable object files (`.o`) or libraries (`.a`) to resolve the remaining unresolved references.

With the linker command line option `--link-only`, you can tell the linker to only perform this linking phase and skip the locating phase. The linker complains if any unresolved references are left.

7.2.2 PHASE 2: LOCATING

In the locating phase, the linker assigns absolute addresses to the object code, placing each section in a specific part of the target memory. The linker also replaces references to symbols by the actual address of those symbols. The resulting file is an absolute object file which you can actually load into a target memory. Optionally, when the resulting file should be loaded into a ROM device the linker creates a so-called copy table section which is used by the startup code to initialize the data and BSS sections.

Code modification

When the linker assigns absolute addresses to the object code, it needs to modify this code according to certain rules or *relocation expressions* to reflect the new addresses. These relocation expressions are stored in the relocatable object file. Consider the following snippet of x86 code that moves the contents of variable `a` to variable `b` via the `eax` register:

```
A1 3412 0000 mov a,%eax (a defined at 0x1234, byte reversed)
A3 0000 0000 mov %eax,b (b is imported so the instruction refers to
                        0x0000 since its location is unknown)
```

Now assume that the linker links this code so that the section in which `a` is located is relocated by 0x10000 bytes, and `b` turns out to be at 0x9A12. The linker modifies the code to be:

```
A1 3412 0100 mov a,%eax (0x10000 added to the address)
A3 129A 0000 mov %eax,b (0x9A12 patched in for b)
```

These adjustments affect instructions, but keep in mind that any pointers in the data part of a relocatable object file have to be modified as well.

Output formats

The linker can produce its output in different file formats. The default ELF/DWARF2 format (`.elf`) contains an image of the executable code and data, and can contain additional debug information. The Intel-Hex format (`.hex`) and Motorola S-record format (`.sre`) only contain an image of the executable code and data. You can specify a format with the options `-F` (`--format`) and `-c` (`--chip-output`).

Controlling the linker

Via a so-called *linker script file* you can gain complete control over the linker. The script language used to describe these features is called the *Linker Script Language* (LSL). You can define:

- The types of memory that are installed in the embedded target system:
 To assign locations to code and data sections, the linker must know what memory devices are actually installed in the embedded target system. For each physical memory device the linker must know its start-address, its size, and whether the memory is read-write accessible (RAM) or read-only accessible (ROM).
- How and where code and data should be placed in the physical memory:
 Embedded systems can have complex memory systems. If for example on-chip and off-chip memory devices are available, the code and data located in internal memory is typically accessed faster and with dissipating less power. To improve the performance of an application, specific code and data sections should be located in on-chip memory. By writing your own LSL file, you gain full control over the locating process.
- The underlying hardware architecture of the target processor.

To perform its task the linker must have a model of the underlying hardware architecture of the processor you are using. For example the linker must know how to translate an address used within the object file (a logical address) into an offset in a particular memory device (a physical address). In most linkers this model is hard coded in the executable and can not be modified. For the **lbc** linker this hardware model is described in the linker script file. This solution is chosen to support configurable cores that are used in system-on-chip designs.



When you want to write your own linker script file, you can use the standard linker script files with architecture descriptions delivered with the product.



See also section 7.7, *Controlling the Linker with a Script*.

7.2.3 LINKER OPTIMIZATIONS

During the linking and locating phase, the linker looks for opportunities to optimize the object code. Both code size and execution speed can be optimized. To enable or disable optimizations:

1. From the **Project** menu, select **Project Options...**

The Project Options dialog box appears.

2. Expand the **Linker** entry and select **Optimization**.

You can enable or disable the optimizations described below. The command line option for each optimization is given in brackets.



See also option **-O** (**--optimize**) in section 5.3, *Linker Options*, in Chapter *Tool Options* of the *TriCore Reference Manual*.

First fit decreasing

(option -O/-OL)

When the physical memory is fragmented or when address spaces are nested it may be possible that a given application cannot be located although the size of available physical memory is larger than the sum of the section sizes. Enable the first-fit-decreasing optimization when this occurs and re-link your application.

The linker's default behavior is to place sections in the order that is specified in the LSL file. This also applies to sections within an unrestricted group. If a memory range is partially filled and a section must be located that is larger than the remainder of this range, then the section and all subsequent sections are placed in a next memory range. As a result of this gaps occur at the end of a memory range.

When the first-fit-decreasing optimization is enabled the linker will first place the largest sections in the smallest memory ranges that can contain the section. Small sections are located last and can likely fit in the remaining gaps.

Copy table compression *(option -Ot/-OT)*

The startup code initializes the application's data and BSS areas. The information about which memory addresses should be zeroed (bss) and which memory ranges should be copied from ROM to RAM is stored in the copy table.

When this optimization is enabled the linker will try to locate sections in such a way that the copy table is as small as possible thereby reducing the application's ROM image.

This optimization reduces both memory and startup speed.

Delete unreferenced code sections *(option -Oc/-OC)*

Delete unreferenced data sections *(option -Od/-OD)*

These two optimizations remove unused sections from the resulting object file. Because debug information normally refers to all sections, these optimizations have no effect until you compile your project without debug information or use linker option **--strip-debug** to remove the debug information.

Delete unreferenced symbols *(option -Os/-OS)*

This optimization tells the linker to remove all unreferenced symbols, such as local assembler symbols.

Delete duplicate code sections *(option -Ox/-OX)*

Delete duplicate data sections *(option -Oy/-OY)*

These two optimizations remove code and constant data that is defined more than once, from the resulting object file.

7.3 CALLING THE LINKER

EDE uses a *makefile* to build your entire project. This means that you cannot run only the linker. However, you can set options specific for the linker. After you have built your project, the output files of the linking step are available in your project directory, unless you specified an alternative output directory in the Build Options dialog.

To link your program, click either one of the following buttons:



Builds your entire project but only updates files that are out-of-date or have been changed since the previous build, which saves time.



Builds your entire project unconditionally. All steps necessary to obtain the final `.elf` file are performed.

To get access to the linker options:

1. From the **Project** menu, select **Project Options...**

The Project Options dialog box appears.

2. Expand the **Linker** entry. Select the subentries and set the options in the various pages.

The command line variant is shown simultaneously.

The following linker options are available:

EDE options	Command line
Output Format	
Output formats	<code>-o[filename][:format [:addr_size][,space]]</code> <code>-c[basename]:format [:addr_size]</code>
Script File	
Select linker script file	<code>-dfile</code>
Map File	
Generate a map file (.map)	<code>-M</code>
<i>Suboptions for the Generate a map file option</i>	<code>-mflags</code>
Libraries	
Link default C libraries Use non-trapping floating-point library Use trapping floating-point library	<code>-lx</code> <code>-lfp</code> <code>-lfpt</code>
Rescan libraries to solve unresolved externals	<code>--no-rescan</code>
Libraries	<i>library files</i>
Optimization	
Use a 'first fit decreasing' algorithm	<code>-Ol/-OL</code> (= on/off)
Use copy table compression	<code>-Ot/-OT</code>
Delete unreferenced symbols	<code>-Os/-OS</code>
Delete unreferenced code sections	<code>-Oc/-OC</code>
Delete unreferenced data sections	<code>-Od/-OD</code>
Delete duplicate code	<code>-Ox/-OX</code>
Delete duplicate constant data	<code>-Oy/-OY</code>
Warnings	
Report all warnings	<i>omit option</i> <code>-w</code>
Suppress all warnings	<code>-w</code>
Suppress specific warnings	<code>-wnum[,num]...</code>
Treat warnings as errors	<code>--warnings-as-errors</code>
Miscellaneous	
(Do not) include symbolic debug information	<code>-S</code> (strip debug)
Print the name of each file as it is processed	<code>-v</code>
Link case sensitive (required for C language)	<code>--case-sensitive</code>

EDE options	Command line
Dump processor and memory info from LSL file	<code>--lsl-dump[=file]</code>
Additional options	<i>options</i>

Table 7-2: Linker options

The following options are only available on the command line:

Description	Command line
Display invocation syntax	<code>-?</code>
Define preprocessor <i>macro</i>	<code>-Dmacro[=def]</code>
Specify a symbol as unresolved external	<code>-esymbol</code>
Redirect errors to a file with extension <code>.elk</code>	<code>--error-file[=file]</code>
Read options from file	<code>-f file</code>
Scan libraries in given order	<code>--first-library-first</code>
Search only in <code>-L</code> directories, not in default path	<code>--ignore-default-library-path</code>
Keep output files after errors	<code>-k</code>
Link only, do not locate	<code>--link-only</code>
Check LSL file(s) and exit	<code>--lsl-check</code>
Do not generate ROM copy	<code>-N</code>
Locate all ROM sections in RAM	<code>--non-romable</code>
Link incrementally	<code>-r</code>
Display version header only	<code>-V</code>

Table 7-3: Linker command line options



The invocation syntax on the command line is:

```
ltc [option]... [file]... ]...
```

When you are linking multiple files (either relocatable object files (`.o`) or libraries (`.a`), it is important to specify the files in the right order. This is explained in Section 7.4.1, *Specifying Libraries to the Linker*



For a complete overview of all options with extensive description, see section 5.3, *Linker Options*, of the *Reference Manual*.

7.4 LINKING WITH LIBRARIES

There are two kinds of libraries: system libraries and user libraries.

System library

The system libraries are installed in subdirectories of the `lib` directory of the toolchain. An overview of the system libraries is given in the following table.

Library to link	Description
<code>libc.a</code>	C library (Some functions require the floating-point library. Also includes the startup code.)
<code>libcs.a</code>	C library single precision (compiler option <code>-F</code>) (Some functions require the floating-point library. Also includes the startup code.)
<code>libcs_fpu.a</code>	C library single precision with FPU instructions (compiler option <code>-F</code> and <code>--fpu-present</code>)
<code>libfp.a</code>	Floating-point library (non-trapping)
<code>libfpt.a</code>	Floating-point library (trapping) (Control program option <code>--fp-trap</code>)
<code>libfp_fpu.a</code>	Floating-point library (non-trapping, with FPU instructions) (Compiler option <code>--fpu-present</code>)
<code>libfpt_fpu.a</code>	Floating-point library (trapping, with FPU instructions) (Control program option <code>--fp-trap</code> , compiler option <code>--fpu-present</code>)
<code>librt.a</code>	Run-time library

Table 7-4: Overview of libraries



For more information on these libraries see section 3.12, *Libraries*, in Chapter *TriCore C Language*.

When you want to link system libraries, you must specify this with the option `-l`. With the option `-lc` you specify the system library `libc.a`.

User library

You can also create your own libraries. Section 8.4, *Archiver*, in Chapter *Using the Utilities*, describes how you can use the archiver to create your own library with object modules. To link user libraries, specify their filenames on the command line.

7.4.1 SPECIFYING LIBRARIES TO THE LINKER

In EDE you can specify both system and user libraries.

Link a system library with EDE

To specify to link the default C libraries:

1. From the **Project** menu, select **Project Options...**
The Project Options dialog box appears.
2. Expand the **Linker** entry and select **Libraries**.
3. Select **Link default C libraries**.
4. Select a floating-point library: **non-trapping** or **trapping**.
5. (Optional) Add the name part of the system libraries to the **Libraries** field. For example, enter **c** to specify the system library **libc.a**.
6. Click **OK** to accept the linker options.



When you want to link system libraries from the command line, you must specify this with the linker option **-l**. With the option **-lc** you specify the system library **libc.a**. For example:

```
ltc -lc start.o
```

Link a user library in EDE

To specify your own libraries, you have to add the library files to your project:

1. From the **Project** menu, select **Properties...**
The Project Properties dialog box appears.
2. In the **Members** tab, click on the **Add existing files to project** button.
3. Select the libraries you want to add and click **Open**.
4. Click **OK** to accept the new project settings.



The invocation syntax on the command line is for example:

```
ltc start.o mylib.a
```

If the library resides in a subdirectory, specify that directory with the library name:

```
ltc start.o mylibs\mylib.a
```

Library order

The order in which libraries appear on the command line is important. By default the linker processes object files and libraries in the order in which they appear on the command line. Therefore, when you use a weak symbol construction, like `printf`, in an object file or your own library, you must position this object/library before the C library.

With the option **--first-library-first** you can tell the linker to scan the libraries from left to right, and extract symbols from the first library where the linker finds it. This can be useful when you want to use newer versions of a library routine.

Example:

```
ltc --first-library-first a.a test.o b.a
```

If the file `test.o` calls a function which is both present in `a.a` and `b.a`, normally the function in `b.a` would be extracted. With this option the linker first tries to extract the symbol from the first library `a.a`.

7.4.2 HOW THE LINKER SEARCHES LIBRARIES

System libraries

You can specify the location of system libraries (specified with option **-l**) in several ways. The linker searches the specified locations in the following order:

1. The linker first looks in the directories that are specified in the **Project | Directories** dialog (**-L** option). If you specify the **-L** option without a pathname, the linker stops searching after this step.
2. When the linker did not find the library (because it is not in the specified library directory or because no directory is specified), it looks which paths were set during installation. You can still change these paths if you like.



See environment variables `LIBTC1V1_2`, `LIBTC1V1_3` and `LIBTC2` in section 1.3.2, *Configuring the Command Line Environment*, in Chapter *Software Installation*.

3. When the linker did not find the library, it tries the default `lib` directory which was created during installation (or a processor specific sub-directory).

User library

If you use your own library, the linker searches the library in the current directory only.

7.4.3 HOW THE LINKER EXTRACTS OBJECTS FROM LIBRARIES

A library built with **artc** always contains an index part at the beginning of the library. The linker scans this index while searching for unresolved externals. However, to keep the index as small as possible, only the defined symbols of the library members are recorded in this area.

When the linker finds a symbol that matches an unresolved external, the corresponding object file is extracted from the library and is processed. After processing the object file, the remaining library index is searched. If after a complete search of the library unresolved externals are introduced, the library index will be scanned again. After all files and libraries are processed, and there are still unresolved externals and you did not specify the linker option **--no-rescan**, all libraries are rescanned again. This way you do not have to worry about the library order. However, this rescanning does not work for 'weak symbols'. If you use a weak symbol construction, like `printf`, in an object file or your own library, you must position this object/library before the C library

The **-v** option shows how libraries have been searched and which objects have been extracted.

Resolving symbols

If you are linking from libraries, only the objects that contain symbol definition(s) to which you refer, are extracted from the library. This implies that if you invoke the linker like:

```
ltc mylib.a
```

nothing is linked and no output file will be produced, because there are no unresolved symbols when the linker searches through `mylib.a`.

It is possible to force a symbol as external (unresolved symbol) with the option **-e**:

```
ltc -e main mylib.a
```

In this case the linker searches for the symbol **main** in the library and (if found) extracts the object that contains **main**. If this module contains new unresolved symbols, the linker looks again in **mylib.a**. This process repeats until no new unresolved symbols are found.

7.5 INCREMENTAL LINKING

With the TriCore linker **ltc** it is possible to link *incrementally*. Incremental linking means that you link some, but not all **.o** modules to a relocatable object file **.out**. In this case the linker does not perform the locating phase. With the second invocation, you specify both new **.o** files and the **.out** file you had created with the first invocation.



Incremental linking is only possible on the command line.

```
ltc -r test1.o -otest.out  
ltc test2.o test.out
```

This links the file **test1.o** and generates the file **test.out**. This file is used again and linked together with **test2.o** to create the file **task1.elf** (the default name if no output filename is given in the default ELF/DWARF 2 format).

With incremental linking it is normal to have unresolved references in the output file until all **.o** files are linked and the final **.out** or **.elf** file has been reached. The option **-r** for incremental linking also suppresses warnings and errors because of unresolved symbols.

7.6 LINKING THE C STARTUP CODE

You need the run-time startup code to build an executable application. The default startup code consists of the following components:

- *Initialization code*. This code is executed when the program is initiated and before the function **main()** is called.
- *Exit code*. This controls the closedown of the application after the program's main function terminates.

- *The trap vector table.* This contains default trap vectors. See also section 3.9.2, *Interrupt and Trap Functions* in Chapter *TriCore C Language*.

The startup code is part of the C library `libc.a`, and the source is present in the file `cstart.asm` in the directory `lib\src`. If the default run-time startup code does not match your configuration, you need to modify the startup code accordingly.

To link the default startup code

1. From the **Project** menu, select **Project Options...**

The Project Options dialog box appears.

2. Expand the **Linker** entry and select **Libraries**.
3. Enable the option **Link default C libraries**.
4. Click **OK** to accept the linker options.

To use your own startup code

1. Make a copy (backup) of the file `lib\src\cstart.asm`.
2. From the **Project** menu, select **Project Options...**

The Project Options dialog box appears.

3. Expand the **Processor** entry and select **Startup**.
4. Enable the option **Automatically copy and link cstart.asm to your project**.
5. Modify the file `cstart.asm` to match your configuration.

EDE adds the startup code to your project, before the libraries. So, the linker finds your startup code first.



See section 4.2, *Startup Code*, in Chapter *Run-time Environment* of the *Reference Manual* for an extensive description of the C startup code.

7.7 CONTROLLING THE LINKER WITH A SCRIPT

With the options on the command line you can control the linker's behavior to a certain degree. From EDE it is also possible to determine where your sections will be located, how much memory is available, which sorts of memory are available, and so on. EDE passes these locating directions to the linker via a script file. If you want even more control over the locating process you can supply your own script.

The language for the script is called the *Linker Script Language*, or shortly LSL. You can specify the script file to the linker, which reads it and locates your application exactly as defined in the script. If you do not specify your own script file, the linker always reads a standard script file which is supplied with the toolchain.

7.7.1 PURPOSE OF THE LINKER SCRIPT LANGUAGE

The Linker Script Language (LSL) serves three purposes:

1. It provides the linker with a definition of the target's core architecture and its *internal* memory (this is called the derivative). These definitions are written by Altium and supplied with the toolchain.
2. It provides the linker with a specification of the *external* memory attached to the target processor. The template `extmem.lsl` is supplied with the toolchain.
3. It provides the linker with information on how your application should be located in memory. This gives you, for example, the possibility to create overlaying sections.

The linker accepts multiple LSL files. You can use the specifications of the TriCore architectures and derivatives that Altium has supplied in the `include.lsl` directory. Do not change these files.

If you attached external memory to a derivative you must specify this in a separate LSL file and pass both the LSL file that describes the derivative's architecture and your LSL file that contains the memory specification to the linker. Next you may also want to specify how sections should be located and overlaid. You can do this in the same file or in another LSL file.

LSL has its own syntax. In addition, you can use the standard C preprocessor keywords, such as `#include` and `#define`, because the linker sends the script file first to the C preprocessor before it starts interpreting the script.



The complete syntax is described in Chapter 8, *Linker Script Language*, in the *Reference Manual*.

7.7.2 EDE AND LSL

In EDE you can specify the size of the stack and heap; the physical memory attached to the processor; identify that particular address ranges are reserved; and specify which sections are located where in memory. EDE translates your input into an LSL file that is stored in the project directory under the name `_project.lsl` and passes this file to the linker.

If you want to learn more about LSL you can inspect the generated file `_project.lsl`.

To change the LSL settings

1. From the **Project** menu, select **Project Options...**

The Project Options dialog box appears.

2. Expand the **Linker** entry and select **Script File**.
3. In each of the pages make your changes.

Each time you close the Project Options dialog the file `_project.lsl` is updated and you can immediately see how your settings are encoded in LSL.

Note that EDE supports ChromaCoding (applying color coding to text) and template expansion when you edit LSL files.

Specify your own LSL file

If you want to write your own linker script file, you can use the EDE generated file `_project.lsl` as an example. Specify this file to EDE as follows:

1. From the **Project** menu, select **Project Options...**

The Project Options dialog box appears.

2. Expand the **Linker** entry and select **Script File**.
3. Select **Use project specific memory and section LSL file** and add your own file in the edit field.

7.7.3 STRUCTURE OF A LINKER SCRIPT FILE

A script file consists of several definitions. The definitions can appear in any order.

The architecture definition (required)

In essence an *architecture definition* describes how the linker should convert logical addresses into physical addresses for a given type of core. If the core supports multiple address spaces, then for each space the linker must know how to perform this conversion. In this context a physical address is an offset on a given internal or external bus. Additionally the architecture definition contains information about items such as the (hardware) stack and the interrupt vector table.

This specification is normally written by Altium. For each TriCore core architecture, a separate LSL file is provided. These are `tc1v1_2.lsl`, `tc1v1_3.lsl`, and `tc2.lsl`. These files include and extend the generic architecture file `tc_arch.lsl`. The generic file `tc_arch.lsl` includes an interrupt vector table (`inttab.lsl`) and an trap vector table (`traptab.lsl`).

The architecture definition of the LSL file should not be changed by you unless you also modify the core's hardware architecture. If the LSL file describes a multi-core system an architecture definition must be available for each different type of core.

The derivative definition (required)

The *derivative definition* describes the configuration of the internal (on-chip) bus and memory system. Basically it tells the linker how to convert offsets on the buses specified in the architecture definition into offsets in internal memory. A derivative definition must be present in an LSL file. Microcontrollers and DSPs often have internal memory and I/O sub-systems apart from one or more cores. The design of such a chip is called a *derivative*.

Altium provides LSL descriptions of supported derivatives, along with "SFR files", which provide easy access to registers in I/O sub-systems from C and assembly programs. When you build an ASIC or use a derivative that is not (yet) supported by the TASKING tools, you may have to write a derivative definition.

When you want to use multiple cores of the same type, you must instantiate the cores in a derivative definition, since the linker automatically instantiates only a single core for an unused architecture.

The processor definition

The *processor definition* describes an instance of a derivative. A processor definition is only needed in a multi-processor embedded system. It allows you to define multiple processors of the same type.

If for a derivative 'A' no processor is defined in the LSL file, the linker automatically creates a processor named 'A' of derivative 'A'. This is why for single-processor applications it is enough to specify the derivative in the LSL file, for example with **-drc1920b.lsl**.

The memory and bus definitions (optional)

Memory and bus definition are used within the context of a derivative definition to specify internal memory and on-chip buses. In the context of a board specification the memory and bus definitions are used to define external (off-chip) memory and buses. Given the above definitions the linker can convert a logical address into an offset into an on-chip or off-chip memory device.

The board specification

The processor definition and memory and bus definitions together form a *board specification*. LSL provides language constructs to easily describe single-core and heterogeneous or homogeneous multi-core systems. The board specification describes all characteristics of your target board's system buses, memory devices, I/O sub-systems, and cores that are of interest to the linker. Based on the information provided in the board specification the linker can for each core:

- convert a logical address to a physical addresses (offsets within a memory device)
- locate sections in physical memory
- maintain an overall view of the used and free physical memory within the whole system while locating

The section layout definition (optional)

The optional *section layout definition* enables you to exactly control where input sections are located. Features are provided such as: the ability to place sections at a given load-address or run-time address, to place sections in a given order, and to overlay code and/or data sections.

Example: Skeleton of a Linker Script File

A linker script file that defines a derivative "X" based on the TC1V1.3 architecture, its external memory and how sections are located in memory, may have the following skeleton:

```

architecture TC1V1.3
{
    // Specification of the TC1v1.3 core architecture.
    // Written by Altium.
}

derivative X           // derivative name is arbitrary
{
    // Specification of the derivative.
    // Written by Altium.
    core tc           // always specify the core
    {
        architecture = TC1V1.3;
    }

    bus fpi_bus       // internal bus
    {
        // maps to fpi_bus in "tc" core
    }

    // internal memory
}

processor spe       // processor name is arbitrary
{
    derivative = X;

    // You can omit this part, except if you use a
    // multi-core system.
}

```

```
memory ext_name
{
    // external memory definition
}

section_layout spe:tc:linear // section layout
{
    // section placement statements

    // sections are located in address space 'linear'
    // of core 'tc' of processor 'spe'
}
```

7.7.4 THE ARCHITECTURE DEFINITION: SELF-DESIGNED CORES

Although you will probably not need to program the architecture definition (unless you are building your own processor core) it helps to understand the Linker Script Language and how the definitions are interrelated.

Within an architecture definition the characteristics of a target processor core that are important for the linking process are defined. These include:

- space definitions: the logical address spaces and their properties
- bus definitions: the I/O buses of the core architecture
- mappings: the address translations between logical address spaces, the connections between logical address spaces and buses and the address translations between buses

Address spaces

A logical address space is a memory range for which the core has a separate way to encode an address into instructions. For example, the Tricore's 32-bit linear address space encloses 16 24-bit sub-spaces and 16 14-bit sub-spaces. See also the *Tricore Architecture Manual* sections "Memory Model" and "Addressing Model".

Most microcontrollers and DSPs support multiple address spaces. An address space is a range of addresses starting from zero. Normally, the size of an address space is to 2^N , with N the number of bits used to encode the addresses.

The relation of an address space with another address space can be one of the following:

- one space is a subset of the other. These are often used for "small" absolute, and relative addressing.
- the addresses in the two address spaces represent different locations so they do not overlap. This means the core must have separate sets of address lines for the address spaces. For example, in Harvard architectures we can identify at least a code and a data memory space.

Address spaces (even nested) can have different minimal addressable units (MAU), alignment restrictions, and page sizes. All address spaces have a number that identifies the logical space (id). The following table lists the different address spaces for the TriCore as defined in the LSL file `tc_arch.lsl`.

Space	Id	MAU	ELF sections
linear	1	8	.text, .bss, .data, .rodata, table, istack, ustack
abs24	2	8	
abs18	3	8	.zdata, .zbss
csa	4	8	csa.* (Context Save Area)
pcp_code	8	16	.pcptext
pcp_data	9	32	.pcpdata

Table 7-5: TriCore address spaces

The TriCore architecture in LSL notation

The best way to program the architecture definition, is to start with a drawing. The following figure shows a part of the TriCore architecture:

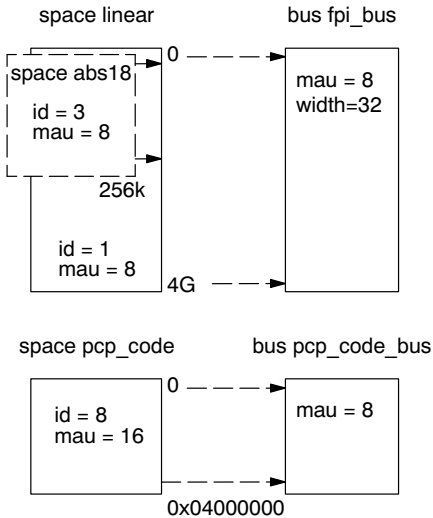

Figure 7-2: Scheme of (part of) the TriCore architecture

The figure shows three address spaces called `linear`, `abs18` and `pcp_code`. The address space `abs18` is a subset of the address space `linear`. All address spaces have attributes like a number that identifies the logical space (`id`), a MAU and an alignment. In LSL notation the definition of these address spaces looks as follows:

```
space linear
{
    id = 1;
    mau = 8;

    map (src_offset=0x00000000, dest_offset=0x00000000,
        size=4G, dest=bus:fpi_bus);
}
```



```

space abs18
{
    id = 3;
    mau = 8;

    map (src_offset=0x00000000, dest_offset=0x00000000,
        size=16k, dest=space:linear);
    map (src_offset=0x10000000, dest_offset=0x10000000,
        size=16k, dest=space:linear);
    map (src_offset=0x20000000, dest_offset=0x20000000,
        size=16k, dest=space:linear);
    //...
}

space pcp_code
{
    id = 8;
    mau = 16;
    map (src_offset=0x00000000, dest_offset=0,
        size=0x04000000, dest=bus:pcp_code_bus);
}

```

The keyword `map` corresponds with the arrows in the drawing. You can map:

- address space => address space
- address space => bus
- memory => bus (not shown in the drawing)
- bus => bus (not shown in the drawing)

Next the two internal buses, named `fpi_bus` and `pcp_code_bus` must be defined in LSL:

```

bus fpi_bus
{
    mau = 8;
    width = 32; // there are 32 data lines on the bus
}

bus pcp_code_bus
{
    mau = 8;
    width = 8;
}

```

This completes the LSL code in the architecture definition. Note that all code above goes into the architecture definition, thus between:

```
architecture TC1V1.3
{
    All code above goes here.
}
```

7.7.5 THE DERIVATIVE DEFINITION: SELF-DESIGNED PROCESSORS

Although you will probably not need to program the derivative definition (unless you are using multiple cores) it helps to understand the Linker Script Language and how the definitions are interrelated.

A derivative is the design of a processor, as implemented on a chip (or FPGA). It comprises one or more cores and on-chip memory. The derivative definition includes:

- core definition: the core architecture
- bus definition: the I/O buses of the core architecture
- memory definitions: internal (or on-chip) memory

Core

Each derivative must have a specification of its core architecture. This core architecture must be defined somewhere in the LSL file(s).

```
core tc
{
    architecture = TC1V1.3;
}
```

Bus

Each derivative must contain a bus definition for connecting external memory. In this example, the bus `fpi_bus` maps to the bus `fpi_bus` defined in the architecture definition of core `tc`:

```
bus fpi_bus
{
    mau = 8;
    width = 32;
    map (dest=bus:tc:fpi_bus, dest_offset=0, size=4G);
}
```

Memory

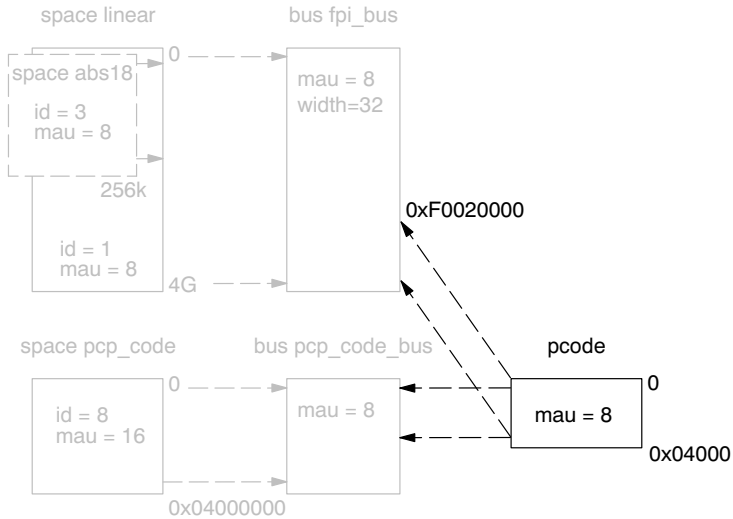

Figure 7-3: Internal memory definition for a derivative

According to the drawing, the TriCore contains internal memory called **pcode** with a size **0x04000** (16k). This is physical memory which is mapped to the internal bus **pcp_code_bus** and to the **fpi_bus**, so both the tc unit and the pcp can access the memory:

```
memory pcode
{
    mau = 8;
    size = 16k;
    type = ram;
    map (dest=bus:tc:fpi_bus, dest_offset=0xF0020000,
        size=16k);
    map (dest=bus:tc:pcp_code_bus, size=16k);
}
```

This completes the LSL code in the derivative definition. Note that all code above goes into the derivative definition, thus between:

```
derivative X // name of derivative
{
    All code above goes here.
}
```



If you want to create a custom derivative and you want to use EDE to select sections, the core of the derivative must be called "tc", since EDE uses this name in the generated LSL file. If you want to specify external memory in EDE, the custom derivative must contain a bus named "fpi_bus" for the same reason. In EDE you have to define a target processor as specified in section 5.4, *Calling the Compiler*, in Chapter *Using the Compiler*.

EDE places a copy of the selected derivative LSL file in your project directory. Any changes you make to the derivative in EDE, for example internal memory, are made to this file.

7.7.6 THE MEMORY DEFINITION: DEFINING EXTERNAL MEMORY

Once the core architecture is defined in LSL, you may want to extend the processor with external (or off-chip) memory. You need to specify the location and size of the physical external memory devices in the target system.

The principle is the same as defining the core's architecture but now you need to fill the memory definition:

```
memory name
{
    External memory definitions.
}
```

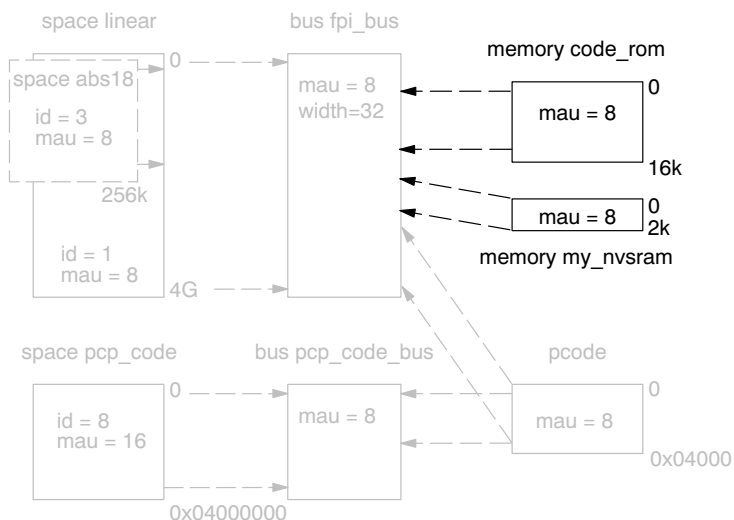

Figure 7-4: Adding external memory to the TriCore architecture

Suppose your embedded system has 16k of external ROM, named **code_rom** and 2k of external NVRAM, named **my_nvram**. (See figure above.) Both memories are connected to the bus **fpi_bus**. In LSL this looks like follows:

```
memory code_rom
{
    type = rom;
    mau = 8;
    size = 16k;
    map (dest=bus:X:fpi_bus, dest_offset=0xa0000000,
        size=16k);
}
```

The memory **my_nvram** is connected to the bus with an offset of 0xc0000000:

```
memory my_nvram
{
    mau = 8;
    size = 2k;
    type = ram;
    map (dest=bus:X:fpi_bus, dest_offset=0xc0000000,
        size=2k);
}
```



If you use a different memory layout than described in the LSL file supplied for the target core, you can specify this in EDE or you can specify this in a separate LSL file and pass both the LSL file that describes the core architecture and your LSL file that contains the memory specification to the linker.

Adding memory using EDE

1. From the **Project** menu, select **Project Options...**

The Project Options dialog box appears.

2. Expand the **Linker** entry.
3. Expand the **Script File** entry and open the **External Memory** page.
4. Add your memory. Specify a name (for example `my_nvram`), type, start address and size, and specify if sections can be located in this memory by default, or not.

7.7.7 THE SECTION LAYOUT DEFINITION: LOCATING SECTIONS

Once you have defined the internal core architecture and optional external memory, you can actually define where your application must be located in the physical memory.

During compilation, the compiler divides the application into sections. Sections have a name, an indication in which address space it should be located and attributes like writable or read-only.

In the section layout definition you can exactly define how input sections are placed in address spaces, relative to each other, and what their absolute run-time and load-time addresses will be. To illustrate section placement the following example of a C program is used:

Example: section propagation through the toolchain

To illustrate section placement, the following example of a C program (`bat.c`) is used. The program saves the number of times it has been executed in battery back-upped memory, and prints the number.

```

#define BATTERY_BACKUP_TAG 0xa5f0
#include <stdio.h>

int uninitialized_data;
int initialized_data = 1;
#pragma section all "non_volatile"
#pragma nclear
int battery_backup_tag;
int battery_backup_invok;
#pragma clear
#pragma section all

void main (void)
{
    if (battery_backup_tag != BATTERY_BACKUP_TAG )
    {
        // battery back-upped memory area contains invalid data
        // initialize the memory
        battery_backup_tag = BATTERY_BACKUP_TAG;
        battery_backup_invok = 0;
    }
    printf( "This application has been invoked %d times\n",
           battery_backup_invok++);
}

```

The compiler assigns names and attributes to sections. With the `#pragma section all "name"` the compiler's default section naming convention is overruled and a section with the name `non_volatile` is defined. In this section the battery back-upped data is stored.

By default the compiler creates the section `.zbss.bat`. `uninitialized_data` to store uninitialized data objects. The section prefix `".zbss"` tells the linker to locate the section in address space `abs18` and that the section content should be filled with zeros at startup.

As a result of the `#pragma section all "non_volatile"`, the data objects between the pragma pair are placed in `.zbss.non_volatile`. Note that `".zbss"` sections are cleared at startup. However, battery back-upped sections should not be cleared and therefore we used the `#pragma nclear`.

The generated assembly may look like:

```

.name    "bat"

.extern printf
.extern __printf_int

.sdecl  ".text.bat.main",CODE
.sect   ".text.bat.main"
.align  4

```

```
        .global main
; Function main
        .extern _start
main:   .type    func
        subl6.a a10,#8
        mov.u   d15,#42480
        ld.w   d0,battery_backup_tag
        jeq    d15,d0,L_2
        .
        .
        .
        j      printf
main_function_end:
        .size   main,main_function_end-main
; End of function
; End of section

        .sdecl  ".zbss.bat.uninitialized_data",DATA
        .sect   ".zbss.bat.uninitialized_data"
        .align  4
        .global uninitialized_data
        .align  2
uninitialized_data:  .type    object
        .size   uninitialized_data,4
        .space  4
; End of section

        .sdecl  ".zdata.bat.initialized_data",DATA
        .sect   ".zdata.bat.initialized_data"
        .align  4
        .global initialized_data
        .align  2
initialized_data:   .type    object
        .size   initialized_data,4
        .word   1
; End of section

        .sdecl  ".zbss.non_volatile",DATA,NOCLEAR
        .sect   ".zbss.non_volatile"
        .align  4
        .global battery_backup_tag
        .align  2
battery_backup_tag: .type    object
        .size   battery_backup_tag,4
        .space  4
        .global battery_backup_invok
        .align  2
battery_backup_invok: .type    object
        .size   battery_backup_invok,4
        .space  4
; End of section
```



```

        .sdecl  ".rodata.bat..1.ini",DATA,ROM
        .sect   ".rodata.bat..1.ini"
        .align  2
    _1_ini: .type  object
        .size   _1_ini,44
        .byte   84 /* T */
        .byte   104 /* h */
        ; This application has been invoked %d times\n
        .byte   10 /* \n */
        .byte   0 /* NULL */

        ; End of section
        ; Module end

```

Section placement

The number of invocations of the example program should be saved in *non-volatile* (battery back-upped) memory. This is the memory `my_nvram` from the example in the previous section.

To control the locating of sections, you need to write one or more section definitions in the LSL file. At least one for each address space where you want to change the default behavior of the linker. In our example, we need to locate sections in the address space `abs18`:

```

section_layout ::abs18
{
    Section placement statements
}

```

To locate sections, you must create a group in which you select sections from your program. For the battery back-up example, we need to define one group, which contains the section `.zbss_non_volatile`. All other sections are located using the defaults specified in the architecture definition. Section `.zbss_non_volatile` should be placed in non-volatile ram. To achieve this, the run address refers to our non-volatile memory called `my_nvram`:

```

group ( ordered, run_addr = mem:my_nvram )
{
    select ".zbss.non_volatile";
}

```

Section placement from EDE

To specify the above settings using EDE, follow these steps:

1. From the **Project** menu, select **Project Options...**

The Project Options dialog box appears.

2. Expand the **Linker** entry.
3. Expand the **Script File** entry and open the **Sections** page.
Here you can specify where sections are located in memory.
4. In the **Space** field, select **abs18**.
5. In the **Sections** field, enter `.zbss.non_volatile`.
6. In the **Group** field, select **ordered**.
7. In the **Copy** field, select **NO**.
8. In the **Alloc** field, select **extmem**. This adds the `mem:` prefix to the location.
9. In the **Location** field, enter `my_nvram`.
10. Optionally enter a group **Name**.
11. Click **OK**.

This completes the LSL file for the sample architecture and sample program. You can now call the linker with this file and the sample program to obtain an application that works for this architecture.



For a complete description of the Linker Script Language, refer to Chapter 8, *Linker Script Language*, in the *Reference Manual*.

7.7.8 THE PROCESSOR DEFINITION: USING MULTI-PROCESSOR SYSTEMS

The processor definition is only needed when you write an LSL-file for a multi-processor embedded system. The processor definition explicitly instantiates a derivative, allowing multiple processors of the same type.

```
processor proc_name
{
    derivative = deriv_name
}
```

If no processor definition is available that instantiates a derivative, a processor is created with the same name as the derivative.

7.8 LINKER LABELS

The linker creates labels that you can use to refer to from within the application software. Some of these labels are real labels at the beginning or the end of a section. Other labels have a second function, these labels are used to address generated data in the locating phase. The data is only generated if the label is used.

Linker labels are labels starting with **_lc_**. The linker assigns addresses to the following labels when they are referenced:

Label	Description
<code>_lc_cp</code>	Start of copy table. Same as <code>_lc_ub_table</code> . The copy table gives the source and destination addresses of sections to be copied. This table will be generated by the linker only if this label is used.
<code>_lc_bh</code>	Begin of heap. Same as <code>_lc_ub_heap</code> .
<code>_lc_eh</code>	End of heap. Same as <code>_lc_ue_heap</code> .
<code>_lc_u_name</code>	User defined label. The label must be defined in the LSL file. For example, <code>"_lc_u_int_tab" = (INTTAB);</code>
<code>_lc_ub_name</code> <code>_lc_b_name</code>	Begin of section <i>name</i> . Also used to mark the begin of the stack or heap or copy table.
<code>_lc_ue_name</code> <code>_lc_e_name</code>	End of section <i>name</i> . Also used to mark the begin of the stack or heap.
<code>_lc_cb_name</code>	Start address of an overlay section in ROM.
<code>_lc_ce_name</code>	End address of an overlay section in ROM.
<code>_lc_gb_name</code>	Begin of group <i>name</i> . This label appears in the output file even if no reference to the label exist in the input file.
<code>_lc_ge_name</code>	End of group <i>name</i> . This label appears in the output file even if no reference to the label exist in the input file.

Table 7-6: Linker labels

The linker only allocates space for the stack and/or heap when a reference to either of the section labels exists in one of the input object files.



If you want to use linker labels in your C source for sections that have a dot (.) in the name, you have to replace all dots by underscores.

Example: refer to a label with section name with dots from C

Suppose the C source file `foo.c` contains the following:

```
int myfunc(int a)
{
    /* some source lines */
}
```

This results in a section with the name `.text.foo.myfunc`

In the following source file `main.c` all dots of the section name are replaced by underscores:

```
extern void *_lc_ub__text_foo_myfunc;

int main(void)
{
    printf("The function myfunc is located at %X\n",
          &_lc_ub__text_foo_myfunc);
}
```

Example: refer to the stack

Suppose in an LSL you have defined a user stack section with the name "ustack" (with the keyword **stack**). You can refer to the begin and end of the stack from your C source as follows:

```
#include <stdio.h>
extern char *_lc_ub_ustack;
extern char *_lc_ue_ustack;
int main()
{
    printf( "Size of user stack is %d\n",
           _lc_ue_ustack - _lc_ub_ustack );
}
```

From assembly you can refer to the end of the user stack with:

```
.extern _lc_ue_ustack ; user stack end
```

7.9 GENERATING A MAP FILE

The map file is an additional output file that contains information about the location of sections and symbols. You can customize the type of information that should be included in the map file.

To generate a map file

1. From the **Project** menu, select **Project Options...**
The Project Options dialog box appears.
2. Expand the **Linker** entry and select **Map File**.
3. Select **Generate a map file (.map)**
4. (Optional) Enable the options to include that information in the map file.

Example on the command line

```
ltc -Mtest.map test.o
```

With this command the list file `test.map` is created.



See section 6.2, *Linker Map File Format*, in Chapter *List File Formats* of the *Reference Manual* for an explanation of the format of the map file.

7.10 LINKER ERROR MESSAGES

The linker produces error messages of the following types:

F Fatal errors

After a fatal error the linker immediately aborts the link/locate process.

E Errors

Errors are reported, but the linker continues linking and locating. No output files are produced unless you have set the linker option **--keep-output-files**.

W Warnings

Warning messages do not result into an erroneous output file. They are meant to draw your attention to assumptions of the linker for a situation which may not be correct. You can control warnings in the **Linker | Warnings** page of the **Project | Project Options...** menu (linker option **-w**).

I Information

Verbose information messages do not indicate an error but tell something about a process or the state of the linker. To see verbose information, use the linker option **-v**.

S System errors

System errors occur when internal consistency checks fail and should never occur. When you still receive the system error message

S6##: message

please report the error number and as many details as possible about the context in which the error occurred. The following helps you to prepare an e-mail using EDE:

1. From the **Help** menu, select **Technical Support -> Prepare Email...**

The Prepare Email form appears.

2. Fill out the the form. State the error number and attach relevant files.
3. Click the **Copy to Email client** button to open your email application.

A prepared e-mail opens in your e-mail application.

4. Finish the e-mail and send it.

Display detailed information on diagnostics

1. In the **Help** menu, enable the option **Show Help on Tool Errors**.
2. In the **Build** tab of the **Output** window, double-click on an error or warning message.

A description of the selected message appears.



```
ltc --diag=[format:]{all | number,...}
```



See linker option **--diag** in section 5.3, *Linker Options* in Chapter *Tool Options* of the *TriCore Reference Manual*.

CHAPTER

8

USING THE UTILITIES

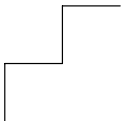

8 | CHAPTER

8.1 INTRODUCTION

The TASKING toolchain for the TriCore processor family comes with a number of utilities that provide useful extra features.

- cctc** A control program for the TriCore toolchain. The control program invokes all tools in the toolchain and lets you quickly generate an absolute object file from C source input files.
- mktc** A utility program to maintain, update, and reconstruct groups of programs. The make utility looks whether files are out of date, rebuilds them and determines which other files as a consequence also need to be rebuild.
- artc** An ELF archiver. With this utility you create and maintain object library files.

8.2 CONTROL PROGRAM

The control program **cctc** is a tool that invokes all tools in the toolchain for you. It provides a quick and easy way to generate the final absolute object file out of your C sources without the need to invoke the compiler, assembler and linker manually.

8.2.1 CALLING THE CONTROL PROGRAM

You can only call the control program from the command line. The invocation syntax is

```
cctc [ option ]... [ file ]... ]...
```

For example:

```
cctc -v test.c
```

The control program calls all tools in the toolchain and generates the absolute object file **test.elf**. With the control program option **-v** you can see how the control program calls the tools:

```
+ c:\ctc\bin\ctc -o test.src test.c
+ c:\ctc\bin\astc -o test.o test.src
+ c:\ctc\bin\ltc -o test.elf -ddefault.lsl
  -dextmem.lsl --map-file test.o -Lc:\ctc\lib\tc1
  -lc -lfp -lrt
```

By default, the control program removes the intermediate output files (**test.src** and **test.o** in the example above) afterwards, unless you specify the command line option **-t** (**--keep-temporary-files**).

Recognized input files

The control program recognizes the following input files:

- Files with a **.cc**, **.cxx** or **.cpp** suffix are interpreted as C++ source programs and are passed to the C++ compiler.
- Files with a **.c** suffix are interpreted as C source programs and are passed to the compiler.
- Files with a **.asm** suffix are interpreted as hand-written assembly source files which have to be passed to the assembler.
- Files with a **.src** suffix are interpreted as compiled assembly source files. They are directly passed to the assembler.

- Files with a `.a` suffix are interpreted as library files and are passed to the linker.
- Files with a `.o` suffix are interpreted as object files and are passed to the linker.
- Files with a `.out` suffix are interpreted as linked object files and are passed to the locating phase of the linker. The linker accepts only one `.out` file in the invocation.
- An argument with a `.lsl` suffix is interpreted as a linker script file and is passed to the linker.

Options of the control program

The following control program options are available:

Description	Option
Information	
Display invocation options	<code>-?</code>
Display version header	<code>-V</code>
Check the source but do not generate code	<code>--check</code>
Show description of diagnostics	<code>--diag={fmt:}{all nr}</code>
Verbose option: show commands invoked	<code>-v</code>
Verbose option: show commands without executing	<code>-n</code>
Suppress all warnings	<code>-w</code>
Treat warnings as errors	<code>--warnings-as-errors</code>
Show C and assembly warnings for C++ compilations	<code>--show-c++-warnings</code>
C Language	
ISO C standard 90 or 99 (default: 99)	<code>--iso={90 99}</code>
Language extensions	<code>-Aflag</code>
Allow C++ style comments in C source	<code>-Ap</code>
Check assignment constant string to non constant string pointer	<code>-Ax</code>
Treat external definitions as "static"	<code>--static</code>
Single precision floating-point	<code>-F</code>
C++ Language	
Treat C++ files as C files	<code>--force-c</code>
Force C++ compilation and linking	<code>--force-c++</code>

Description	Option
Force invocation of C++ muncher	--force-munch
Force invocation of C++ prelinker	--force-prelink
Show the list of object files handled by the C++ prelinker	--list-object-files
Copy C++ prelink (.ii) files from outside the current directory	--prelink-copy-if-nonlocal
Use only C++ prelink files in the current directory	--prelink-local-only
Remove C++ instantiation flags after prelinking	--prelink-remove-instantiation-flags
Enable C++ exception handling	--exceptions
C++ instantiation mode	--instantiate=type
C++ instantiation directory	--instantiation-dir=dir
C++ instantiation file	--instantiation-file=file
Disable automatic C++ instantiation	--no-auto-instantiation
Allow multiple instantiations in a single object file	--no-one-instantiation-per-object
Preprocessing	
Define preprocessor <i>macro</i>	-Dmacro[=def]
Remove preprocessor <i>macro</i>	-Umacro
Store the C compiler preprocess output (<i>file.pre</i>)	-Eflag
Code generation	
Select CPU type	-Ccpu
Generate symbolic debug information	-g
Use hardware floating-point instructions	--fpu-present
Allow use of TriCore2 instructions	--is-tricore2
Allow use of MMU instructions	--mmu-present
Enable silicon bug workaround	--silicon-bug=arg,...
Libraries	
Add library directory	-Ldir
Add library	-llib

Description	Option
Ignore the default search path for libraries	--ignore-default-library-path
Do not include default list of libraries	--no-default-libraries
Use trapped floating-point library	--fp-trap
Input files	
Specify linker script file	-d file
Read options from file	-f file
Add include directory	-ldir
Do not include the SFR file as indicated by -C	--no-tasking-sfr
Output files	
Redirect diagnostic messages to a file	--error-file
Select final output file: C file	-cc
relocatable output file	-cl
object file(s)	-co
assembly file(s)	-cs
Specify linker output format (ELF, IEEE)	--format=type
Set the address size for linker IHEX/SREC files	--address-size=n
Set linker output space name	--space=name
Keep output file(s) after errors	-k
Do not generate linker map file	--no-map-file
Specify name of output file	-o file
Do not delete intermediate (temporary) files	-t

Table 8-1: Overview of control program options



For a complete list and description of all control program options, see section 5.4, *Control Program Options*, in Chapter *Tool Options* of the *Reference Manual*.

The options in table 8-1 are options that the control program interprets itself. The control program however can also pass an option directly to a tool. Such an option is not interpreted by the control program but by the tool itself. The next example illustrates how an option is passed directly to the linker to link a user defined library:

```
cctc -Wlk-lmylib test.c
```

Use the following options to pass arguments to the various tools:

Description	Option
Pass argument directly to the C++ compiler	-Wcparg
Pass argument directly to the C++ pre-linker	-Wplarg
Pass argument directly to the C compiler	-Wcarg
Pass argument directly to the assembler	-Waarg
Pass argument directly to the PCP assembler	-Wpcparg
Pass argument directly to the linker	-Wlarg

Table 8-2: Control program options to pass an option directly to a tool



If you specify an unknown option to the control program, the control program looks if it is an option for a specific tool. If so, it passes the option directly to the tool. However, it is recommended to use the control program options to passing arguments directly to tools.

With the environment variable CCTCOPT you can define options and/or arguments that the control programs always processes *before* the command line arguments.

For example, if you use the control program always with the option **--no-map-file** (do not generate a linker map file), you can specify "--no-map-file" to the environment variable CCTCOPT.



See section 1.3.2, *Configuring the Command Line Environment*, in Chapter *Software Installation*.

8.3 MAKE UTILITY

If you are working with large quantities of files, or if you need to build several targets, it is rather time-consuming to call the individual tools to compile, assemble, link and locate all your files.

You save already a lot of typing if you use the control program **cctc** and define an options file. You can even create a batch file or script that invokes the control program for each target you want to create. But with these methods *all* files are completely compiled, assembled, linked and located to obtain the target file, even if you changed just one C source. This may demand a lot of (CPU) time on your host.

The make utility **mktc** is a tool to maintain, update, and reconstruct groups of programs. The make utility looks which files are out-of-date and only recreates these files to obtain the updated target.

Make process

In order to build a target, the make utility needs the following input:

- the target it should build, specified as argument on the command line
- the rules to build the target, stored in a file usually called **makefile**



In addition, the make utility also reads the file **mktc.mk** which contains predefined rules and macros. See section 8.3.2, *Writing a Makefile*.

The makefile contains the relationships among your files (called *dependencies*) and the commands that are necessary to create each of the files (called *rules*). Typically, the absolute object file (**.elf**) is updated when one of its dependencies has changed. The absolute file depends on **.o** files and libraries that must be linked together. The **.o** files on their turn depend on **.src** files that must be assembled and finally, **.src** files depend on the C source files (**.c**) that must be compiled. In the makefile **makefile** this looks like:

```
test.src : test.c                # dependency
          ctc test.c             # rule

test.o   : test.src
          astc test.src

test.elf : test.o
          ltc -otest.elf test.o -lc -lfp -lrt
```

You can use any command that is valid on the command line as a rule in the `makefile`. So, rules are not restricted to invocation of the toolchain.

Example

To build the target `test.elf`, call **mktc** with one of the following lines:

```
mktc test.elf
```

```
mktc -f mymake.mak test.elf
```



By default, the make utility reads `makefile` so you do not need to specify it on the command line. If you want to use another name for the makefile, use the option `-f my_makefile`.



If you do not specify a target, **mktc** uses the first target defined in the makefile. In this example it would build `test.src` instead of `test.elf`.

The make utility now tries to build `test.elf` based on the `makefile` and performs the following steps:

1. From the makefile the make utility reads that `test.elf` depends on `test.o`.
2. If `test.o` does not exist or is out-of-date, the make utility first tries to build this file and reads from the makefile `test.o` depends on `test.src`.
3. If `test.src` does exist, the make utility now creates `test.o` by executing the rule for it: `astc test.src`.
4. There are no other files necessary to create `test.elf` so the make utility now can use `test.o` to create `test.elf` by executing the rule `ltc -otest.elf test.o -lc -lfp -lrt`.

The make utility has now built `test.elf` but it only used the assembler to update `test.o` and the linker to create `test.elf`.

If you compare this to the control program:

```
cctc test.c
```

This invocation has the same effect but now *all* files are recompiled (assembled, linked and located).

8.3.1 CALLING THE MAKE UTILITY

You can only call the make utility from the command line. The invocation syntax is

```
mktc [ options ] [ targets ] [ macro=def ]... ]
```

For example:

```
mktc test.elf
```

target You can specify any target that is defined in the makefile. A target can also be one of the intermediate files specified in the makefile.

macro=def Macro definition. This definition remains fixed for the **mktc** invocation. It overrides any regular definitions for the specified macro within the makefiles and from the environment. It is inherited by subordinate **mktc**'s but act as an environment variable for these. That is, depending on the **-e** setting, it may be overridden by a makefile definition.

Exit status

The make utility returns an exit status of 1 when it halts as a result of an error. Otherwise it returns an exit status of 0.

Options of the make utility

The following make utility options are available:

Description	Option
Display options	-?
Display version header	-V
Verbose	
Print makefile lines while being read	-D/-DD
Display time comparisons which indicate a target is out of date	-d/-dd
Display current date and time	-time
Verbose option: show commands without executing (dry run)	-n
Do not show commands before execution	-s
Do not build, only indicate whether target is up-to-date	-q

Description	Option
Input files	
Use <i>makefile</i> instead of the standard makefile <i>makefile</i>	-f <i>makefile</i>
Change to directory before reading the makefile	-G <i>path</i>
Read options from file	-m <i>file</i>
Do not read the <i>mktc.mk</i> file	-r
Process	
Always rebuild target without checking whether it is out-of-date	-a
Run as a child process	-c
Environment variables override macro definitions	-e
Do not remove temporary files	-K
On error, only stop rebuilding current target	-k
Overrule the option -k (only stop rebuilding current target)	-S
Make all target files precious	-p
Touch the target files instead of rebuilding them	-t
Treat target as if it has just been reconstructed	-W <i>target</i>
Error messages	
Redirect error messages and verbose messages to a file	-err <i>file</i>
Ignore error codes returned by commands	-i
Redirect messages to standard out instead of standard error	-w
Show extended error messages	-x

Table 8-3: Overview of control program options



For a complete list and description of all control program options, see section 5.5, *Make Utility Options*, in Chapter *Tool Options* of the *Reference Manual*.

8.3.2 WRITING A MAKEFILE

In addition to the standard makefile *makefile*, the make utility always reads the makefile *mktc.mk* before other inputs. This system makefile contains implicit rules and predefined macros that you can use in the makefile *makefile*.



With the option **-r** (Do not read the *mktc.mk* file) you can prevent the make utility from reading *mktc.mk*.

The default name of the makefile is *makefile* in the current directory. If on a UNIX system this file is not found, the file *Makefile* is used as the default. If you want to use other makefiles, use the option **-f** *my_makefile*.

The makefile can contain a mixture of:

- targets and dependencies
- rules
- macro definitions or functions
- comment lines
- include lines
- export lines

To continue a line on the next line, terminate it with a backslash (\):

```
# this comment line is continued\  
on the next line
```

If a line must end with a backslash, add an empty macro.

```
# this comment line ends with a backslash \$(EMPTY)  
# this is a new line
```

Targets and dependencies

The basis of the makefile is a set of targets, dependencies and rules. A target entry in the makefile has the following format:

```
target ... : [dependency ...] [; rule]  
[rule]  
...
```

Target lines must always start at the beginning of a line, leading white spaces (tabs or spaces) are not allowed. A target line consists of one or more targets, a semicolon and a set of files which are required to build the target (*dependencies*). The target itself can be one or more filenames or symbolic names.:

```
all:                demo.elf final.elf  
  
demo.elf final.elf: test.o demo.o final.o
```

You can now specify the target you want to build to the make utility. The following three invocations all have the same effect:

```
mktc  
mktc all  
mktc demo.elf final.elf
```

If you do *not* specify a target, the first target in the makefile (in this example `all`) is built. The target `all` depends on `demo.elf` and `final.elf` so the second and third invocation have also the same effect and the files `demo.elf` and `final.elf` are built.



In MS-Windows you can normally use colons to denote drive letters. The following works as intended: `c:foo.o : a:foo.c`

If a target is defined in more than one target line, the dependencies are added to form the target's complete dependency list:

```
all: demo.elf # These two lines are equivalent with:
all: final.elf # all: demo.elf final.elf
```

For target lines, macros and functions are expanded at the moment they are read by the make utility. Normally macros are not expanded until the moment they are actually used.

Special Targets

There are a number of special targets. Their names begin with a period.

- .DEFAULT: If you call the make utility with a target that has no definition in the makefile, this target is built.
- .DONE: When the make utility has finished building the specified targets, it continues with the rules following this target.
- .IGNORE: Non-zero error codes returned from commands are ignored. Encountering this in a makefile is the same as specifying the option `-i` on the command line.
- .INIT: The rules following this target are executed before any other targets are built.
- .SILENT: Commands are not echoed before executing them. Encountering this in a makefile is the same as specifying the option `-s` on the command line.
- .SUFFIXES: This target specifies a list of file extensions. Instead of building a completely specified target, you now can build a target that has a certain file extension. Implicit rules to build files with a number of extensions are included in the system makefile `mktc.mk`.

If you specify this target with dependencies, these are added to the existing `.SUFFIXES` target in `mktc.mk`. If you specify this target without dependencies, the existing list is cleared.

`.PRECIOUS`: Dependency files mentioned for this target are never removed. Normally, if a command in a rule returns an error or when the target construction is interrupted, the make utility removes that target file. You can use the `-p` command line option to make all target files precious.

Rules

A line with leading white space (tabs or spaces) is considered as a rule and associated with the most recently preceding dependency line. A *rule* is a line with commands that are executed to build the associated target. A target-dependency line can be followed by one or more rules.

```
final.src : final.c          # target and dependency
           mv test.c final.c # rule1
           ctc final.c       # rule2
```

You can precede a rule with one or more of the following characters:

- @ does not echo the command line, except if `-n` is used.
- the make utility ignores the exit code of the command (`ERRORLEVEL` in MS-DOS). Normally the make utility stops if a non-zero exit code is returned. This is the same as specifying the option `-i` on the command line or specifying the special `.IGNORE` target.
- + The make utility uses a shell or `COMMAND.COM` to execute the command. If the '+' is not followed by a shell line, but the command is a DOS command or if redirection is used (`<`, `|`, `>`), the shell line is passed to `COMMAND.COM` anyway. For UNIX, redirection, backquote (```) parentheses and variables force the use of a shell.

You can force `mktc` to execute multiple command lines in one shell environment. This is accomplished with the token combination `;\`. For example:

```
cd c:\ctc\bin ;\
ctc -V
```



The ';' must always directly be followed by the '\\' token. Whitespace is not removed when it is at the end of the previous command line or when it is in front of the next command line. The use of the ';' as an operator for a command (like a semicolon ';' separated list with each item on one line) and the '\\' as a layout tool is not supported, unless they are separated with whitespace.

The make utility can generate inline temporary files. If a line contains <<LABEL (no whitespaces!) then all subsequent lines are placed in a temporary file until the line LABEL is encountered. Next, <<LABEL is replaced by the name of the temporary file.

Example:

```
ltc -o $@ -f <<EOF
    $(separate "\n" $(match .o $!))
    $(separate "\n" $(match .a $!))
    $(LKFLAGS)
EOF
```

The three lines between <<EOF and EOF are written to a temporary file (for example mkce4c0a.tmp), and the rule is rewritten as `ltc -o $@ -f mkce4c0a.tmp`.

Instead of specifying a specific target, you can also define a general target. A general target specifies the rules to generate a file with extension `.ex1` to a file with extension `.ex2`. For example:

```
.SUFFIXES: .c
.c.src    :
          ltc $<
```

Read this as: to build a file with extension `.src` out of a file with extension `.c`, call the compiler with `$<`. `$<` is a predefined macro that is replaced with the basename of the specified file. The special target `.SUFFIXES:` is followed by a list of file extensions of the files that are required to build the target.

Implicit Rules

Implicit rules are stored in the system makefile `mkctc.mk` and are intimately tied to the `.SUFFIXES` special target. Each dependency that follows the `.SUFFIXES` target, defines an extension to a filename which must be used to build another file. The implicit rules then define how to actually build one file from another. These files share a common basename, but have different extensions.

If the specified target on the command line is not defined in the makefile or has not rules in the makefile, the make utility looks if there is an implicit rule to build the target.

Example

This makefile says that `prog.out` depends on two files `prog.o` and `sub.o`, and that they in turn depend on their corresponding source files (`prog.c` and `sub.c`) along with the common file `inc.h`.

```
LIB =      -lc                                # macro

prog.elf: prog.o sub.o
    ldc prog.o sub.o $(LIB) -o prog.elf

prog.o: prog.c inc.h
    ldc prog.c
    astc prog.src

sub.o: sub.c inc.h
    ldc sub.c
    astc sub.src
```

The following makefile uses implicit rules (from `mktc.mk`) to perform the same job.

```
LKFLAGS = -lc                                # macro used by implicit rules
prog.elf: prog.o sub.o                        # implicit rule used
prog.o: prog.c inc.h                          # implicit rule used
sub.o: sub.c inc.h                            # implicit rule used
```

Files

<code>makefile</code>	Description of dependencies and rules.
<code>Makefile</code>	Alternative to <code>makefile</code> , for UNIX.
<code>mktc.mk</code>	Default dependencies and rules.

Diagnostics

mktc returns an exit status of 1 when it halts as a result of an error. Otherwise it returns an exit status of 0.

Macro definitions

A macro is a symbol name that is replaced with its definition before the makefile is executed. Although the macro name can consist of lower case or upper case characters, upper case is an accepted convention. The general form of a macro definition is:

```
MACRO = text and more text
```

Spaces around the equal sign are not significant. To use a macro, you must access it's contents:

```
$(MACRO)      # you can read this as
${MACRO}      # the contents of macro MACRO
```

If the macro name is a single character, the parentheses are optional. Note that the expansion is done recursively, so the body of a macro may contain other macros. These macros are expanded when the macro is actually used, not at the point of definition:

```
FOOD = $(EAT) and $(DRINK)
EAT = meat and/or vegetables
DRINK = water
export FOOD
```

The macro `FOOD` is expanded as `meat and/or vegetables and water` at the moment it is used in the `export` line.

Predefined Macros

MAKE Holds the value `mktc`. Any line which uses **MAKE**, temporarily overrides the option **-n** (Show commands without executing), just for the duration of the one line. This way you can test nested calls to **MAKE** with the option **-n**.

MAKEFLAGS Holds the set of options provided to **mktc** (except for the options **-f** and **-d**). If this macro is exported to set the environment variable **MAKEFLAGS**, the set of options is processed before any command line options. You can pass this macro explicitly to nested **mktc**'s, but it is also available to these invocations as an environment variable.

PRODDIR Holds the name of the directory where **mktc** is installed. You can use this macro to refer to files belonging to the product, for example a library source file.

```
DOPRINT = $(PRODDIR)/lib/src/_doprint.c
```

When **mktc** is installed in the directory `/ctc/bin` this line expands to:

```
DOPRINT = /ctc/lib/src/_doprint.c
```

SHELLCMD Holds the default list of commands which are local to the SHELL. If a rule is an invocation of one of these commands, a SHELL is automatically spawned to handle it.

TMP_CCPROG

Holds the name of the control program: **cctc**. If this macro and the **TMP_CCOPT** macro are set and the command line argument list for the control program exceeds 127 characters, then **mktc** creates a temporary file with the command line arguments. **mktc** calls the control program with the temporary file as command input file.

TMP_CCOPT

Holds **-f**, the control program option that tells it to read options from a file. (This macro is only available for the Windows command prompt version of **mktc**.)

\$ This macro translates to a dollar sign. Thus you can use **\$\$\$** in the makefile to represent a single **\$**.

There are several dynamically maintained macros that are useful as abbreviations within rules. It is best not to define them explicitly.

\$* The basename of the current target.

\$< The name of the current dependency file.

\$@ The name of the current target.

\$? The names of dependents which are younger than the target.

! The names of all dependents.

The **\$<** and **\$*** macros are normally used for implicit rules. They may be unreliable when used within explicit target command lines. All macros may be suffixed with **F** to specify the Filename components (e.g. **\${*F}**, **#{@F}**). Likewise, the macros **\$***, **\$<** and **\$@** may be suffixed by **D** to specify the directory component.



The result of the **\$*** macro is always without double quotes (**"**), regardless of the original target having double quotes (**"**) around it or not. The result of using the suffix **F** (Filename component) or **D** (Directory component) is also always without double quotes (**"**), regardless of the original contents having double quotes (**"**) around it or not.

Functions

A function not only expands but also performs a certain operation. Functions syntactically look like macros but have embedded spaces in the macro name, e.g. `$(match arg1 arg2 arg3)`. All functions are built-in and currently there are five of them: `match`, `separate`, `protect`, `exist` and `nexist`.

match The `match` function yields all arguments which match a certain suffix:

```
$(match .o prog.o sub.o mylib.a)
```

yields:

```
prog.o sub.o
```

separate The `separate` function concatenates its arguments using the first argument as the separator. If the first argument is enclosed in double quotes then `'\n'` is interpreted as a newline character, `'\t'` is interpreted as a tab, `'\ooo'` is interpreted as an octal value (where, `ooo` is one to three octal digits), and spaces are taken literally. For example:

```
$(separate "\n" prog.o sub.o)
```

results in:

```
prog.o
sub.o
```

Function arguments may be macros or functions themselves. So,

```
$(separate "\n" $(match .o $!))
```

yields all object files the current target depends on, separated by a newline string.

protect The `protect` function adds one level of quoting. This function has one argument which can contain white space. If the argument contains any white space, single quotes, double quotes, or backslashes, it is enclosed in double quotes. In addition, any double quote or backslash is escaped with a backslash.

Example:

```
echo $(protect I'll show you the "protect"
function)
```

yields:

```
echo "I'll show you the \"protect\"
function"
```

exist The **exist** function expands to its second argument if the first argument is an existing file or directory.

Example:

```
$(exist test.c cctc test.c)
```

When the file **test.c** exists, it yields:

```
cctc test.c
```

When the file **test.c** does not exist nothing is expanded.

nexist The **nexist** function is the opposite of the **exist** function. It expands to its second argument if the first argument is not an existing file or directory.

Example:

```
$(nexist test.src cctc test.c)
```

Conditional Processing

Lines containing **ifdef**, **ifndef**, **else** or **endif** are used for conditional processing of the makefile. They are used in the following way:

```
ifdef macro-name
if-lines
else
else-lines
endif
```

The *if-lines* and *else-lines* may contain any number of lines or text of any kind, even other **ifdef**, **ifndef**, **else** and **endif** lines, or no lines at all. The **else** line may be omitted, along with the *else-lines* following it.

First the *macro-name* after the `if` command is checked for definition. If the macro is defined then the *if-lines* are interpreted and the *else-lines* are discarded (if present). Otherwise the *if-lines* are discarded; and if there is an `else` line, the *else-lines* are interpreted; but if there is no `else` line, then no lines are interpreted.

When using the `ifndef` line instead of `ifdef`, the macro is tested for not being defined. These conditional lines can be nested up to 6 levels deep.



See also *Defining Macros* in section 5.5, *Make Utility Options*, in Chapter *Tools Options of the Reference Manual*.

Comment lines

Anything after a `"#"` is considered as a comment, and is ignored. If the `"#"` is inside a quoted string, it is not treated as a comment. Completely blank lines are ignored.

```
test.src : test.c      # this is comment and is
                  ctc test.c # ignored by the make utility
```

Include lines

An *include* line is used to include the text of another makefile (like including a `.h` file in a C source). Macros in the name of the included file are expanded before the file is included. Include files may be nested.

```
include makefile2
```

Export lines

An *export* line is used to export a macro definition to the environment of any command executed by the make utility.

```
GREETING = Hello

export GREETING
```

This example creates the environment variable `GREETING` with the value `Hello`. The macros is exported at the moment the export line is read so the macro definition has to proceed the export line.

8.4 ARCHIVER

The archiver **artc** is a program to build and maintain your own library files. A library file is a file with extension **.a** and contains one or more object files (**.o**) that may be used by the linker.

The archiver has five main functionalities:

- Deleting an object module from the library
- Moving an object module to another position in the library file
- Replacing an object module in the library or add a new object module
- Showing a table of contents of the library file
- Extracting an object module from the library

The archiver takes the following files for input and output:

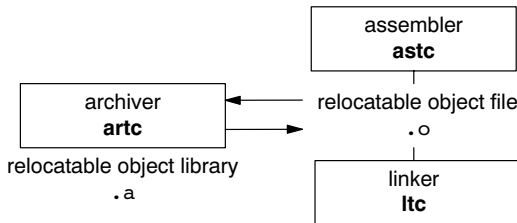

Figure 8-1: **artc** ELF/DWARF archiver and library maintainer

The linker optionally includes object modules from a library if that module resolves an external symbol definition in one of the modules that are read before.

8.4.1 CALLING THE ARCHIVER

You can only call the archiver from the command line. The invocation syntax is:

```
artc key_option [sub_option...] library [object_file]
```

key_option With a key option you specify the main task which the archiver should perform. You must *always* specify a key option.

- sub_option* Sub-options specify into more detail how the archiver should perform the task that is specified with the key option. It is not obligatory to specify sub-options.
- library* The name of the library file on which the archiver performs the specified action. You must always specify a library name, except for the option **-?** and **-V**. When the library is not in the current directory, specify the complete path (either absolute or relative) to the library.
- object_file* The name of an object file. You must always specify an object file name when you add, extract, replace or remove an object file from the library.

Options of the archiver utility

The following archiver options are available:

Description	Option	Sub-option
Main functions (key options)		
Replace or add an object module	-r	-a -b -c -u -v
Extract an object module from the library	-x	-v
Delete object module from library	-d	-v
Move object module to another position	-m	-a -b -v
Print a table of contents of the library	-t	-s0 -s1
Print object module to standard output	-p	
Sub-options		
Append or move new modules after existing module <i>name</i>	-a name	
Append or move new modules before existing module <i>name</i>	-b name	
Create library without notification if library does not exist	-c	
Preserve last-modified date from the library	-o	
Print symbols in library modules	-s{0 1}	
Replace only newer modules	-u	
Verbose	-v	

Description	Option	Sub-option
Miscellaneous		
Display options	-?	
Display version header	-V	
Read options from <i>file</i>	-f <i>file</i>	
Suppress warnings above level <i>n</i>	-wn	

Table 8-4: Overview of archiver options and sub-options



For a complete list and description of all archiver options, see section 5.6, *Archiver Options*, in Chapter *Tool Options* of the *Reference Manual*.

8.4.2 EXAMPLES

Create a new library

If you add modules to a library that does not yet exist, the library is created. To create a new library with the name `mylib.a` and add the object modules `cstart.o` and `calc.o` to it:

```
artc -r mylib.a cstart.o calc.o
```

Add a new module to an existing library

If you add a new module to an existing library, the module is added at the end of the module. (If the module already exists in the library, it is replaced.)

```
artc -r mylib.a mod3.o
```

Print a list of object modules in the library

To inspect the contents of the library:

```
artc -t mylib.a
```

The library has the following contents:

```
cstart.o
calc.o
mod3.o
```

Move an object module to another position

To move `mod3.o` to the beginning of the library, position it just before `cstart.o`:

```
artc -mb cstart.o mylib.a mod3.o
```

Delete an object module from the library

To delete the object module `cstart.o` from the library `mylib.a`:

```
artc -d mylib.a cstart.o
```

Extract all modules from the library

Extract all modules from the library `mylib.a`:

```
artc -x mylib.a
```

INDEX

INDEX

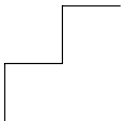

INDEX

Symbols

`__asm`
syntax, 3-19
writing intrinsics, 3-23

`__BUILD__`, 3-28

`__circ`, 3-15

`__REVISION__`, 3-28

`__VERSION__`, 3-28

A

absolute address, 3-13

absolute variable, 3-13

address space, 7-25

addressing modes, 4-5

- absolute*, 4-6
- base + offset*, 4-6
- bit-reverse*, 4-7
- circular*, 4-7
- indexed*, 4-7
- PCP assembler*, 4-8
- post-increment*, 4-6
- pre-increment*, 4-6

architecture definition, 7-22, 7-25

archiver, 8-23

- invocation*, 8-23
- options (overview)*, 8-24

artc, 8-23

assembler, setting options, 6-6

assembler controls, overview, 4-21

assembler directives, overview, 4-18

assembler error messages, 6-9

assembler options, overview, 6-6

assembly, programming in C, 3-19

assembly syntax, 4-3

B

backend

- compiler phase*, 5-5
- optimization*, 5-5

board specification, 7-23

buffers, circular, 3-15

build, viewing results, 2-16

bus definition, 7-23

C

C preprocessor, 7-21

cctc, 8-4

CCTCOPT, 8-8

character, 4-4

circular buffers, 3-15

coalescer, 5-8

code checking, 5-16

code generator, 5-5

common subexpression elimination,
 5-6

compile, 2-16

compiler

- invocation*, 5-10
- optimizations*, 5-5
- setting options*, 5-11

compiler error messages, 5-19

compiler options, overview, 5-12

compiler phases

- backend*, 5-4
- code generator phase*, 5-5
- optimization phase*, 5-5
- peephole optimizer phase*, 5-5
- pipeline scheduler*, 5-5

frontend, 5-4
 optimization phase, 5-4
 parser phase, 5-4
 preprocessor phase, 5-4
 scanner phase, 5-4
 conditional assembly, 4-31
 conditional jump reversal, 5-7
 configuration
 EDE directories, 1-7
 UNIX, 1-9
 constant propagation, 5-6
 continuation, 4-23
 control flow simplification, 5-7
 control program, 8-4
 invocation, 8-4
 options (overview), 8-5
 control program options, overview,
 8-5, 8-11, 8-24
 controls, 4-4
 copy table, compression, 7-10
 creating a makefile, 2-13
 CSE, 5-6

D

data type qualifiers, 3-15
 data types, 3-3
 accumulator, 3-5
 bit, 3-6
 fractional, 3-5
 fundamental, 3-3
 packed, 3-8
 dead code elimination, 5-7
 delete duplicate code sections, 7-10
 delete duplicate constant data, 7-10
 delete unreferenced sections, 7-10
 delete unreferenced symbols, 7-10
 derivative definition, 7-22, 7-29
 directive, conditional assembly, 4-31
 directives, 4-4
 directories, setting, 1-7, 1-9

E

EDE, 2-3
 build an application, 2-16
 create a project, 2-11
 create a project space, 2-9
 rebuild an application, 2-17
 specify development tool options,
 2-14
 starting, 2-8
 ELF/DWARF, archiver, 8-23
 ELF/DWARF2 format, 7-8
 Embedded Development Environment,
 2-3
 environment variables, 1-9
 ASPCPINC, 1-9
 ASTCINC, 1-9
 CCTCBIN, 1-9
 CCTCOPT, 1-9, 8-8
 CTCINC, 1-9
 LIBTC1V1_2, 1-10
 LIBTC1V1_3, 1-10
 LIBTC2, 1-10
 LM_LICENSE_FILE, 1-10, 1-16
 PATH, 1-9
 TASKING_LIC_WAIT, 1-10
 TMPDIR, 1-10
 error messages
 assembler, 6-9
 compiler, 5-19
 linker, 7-41
 expression simplification, 5-6
 expressions, 4-9
 absolute, 4-9
 relative, 4-9
 relocatable, 4-9

F

file extensions, 2-6

first fit decreasing, 7-9
 fixed-point specifiers, 3-47
 floating license, 1-12
 flow simplification, 5-7
 formatters
 printf, 3-46
 scanf, 3-46
 forward store, 5-7
 fractional data types, operations, 3-6
 frontend
 compiler phase, 5-4
 optimization, 5-4
 function, 4-14
 syntax, 4-14
 function qualifiers
 __bisr__, 3-36
 __enable__, 3-36
 __indirect, 3-37
 __interrupt, 3-32
 __stackparm, 3-37
 __syscallfunc, 3-34
 __trap, 3-33
 functions, 3-29

H

hostid, determining, 1-17
 hostname, determining, 1-17

I

IF conversion, 5-8
 include files
 default directory, 5-15, 6-8, 7-17
 setting search directories, 1-7, 1-9
 incremental linking, 7-18
 inline assembly
 __asm, 3-19
 writing intrinsics, 3-23
 inline functions, 3-29
 inlining functions, 5-7

input specification, 4-3
 installation
 licensing, 1-12
 Linux, 1-4
 Debian, 1-5
 RPM, 1-4
 tar.gz, 1-5
 UNIX, 1-6
 Windows 95/98/XP/NT/2000, 1-3
 instruction scheduler, 5-8
 instructions, 4-4
 Intel-Hex format, 7-8
 interrupt function, 3-31
 interrupt request
 disabling, 3-32, 3-36
 enabling, 3-36
 interrupt service routine, 3-31
 defining, 3-32
 intrinsic functions, 3-18

J

jump chain, 3-44
 jump chaining, 5-7
 jump table, 3-44

L

labels, 4-3, 4-8
 libraries
 rebuilding, 3-48
 setting search directories, 1-8, 1-10
 library, user, 7-14
 library maintainer, 8-23
 license
 floating, 1-12
 node-locked, 1-12
 obtaining, 1-12
 wait for available license, 1-10
 license file
 location, 1-16

- setting search directory*, 1-10
- licensing, 1-12
- linker, optimizations, 7-9
- linker error messages, 7-41
- linker options, overview, 7-12
- linker output formats
 - ELF/DWARF2 format*, 7-8
 - Intel-Hex format*, 7-8
 - Motorola S-record format*, 7-8
- linker script file, 7-8
 - architecture definition*, 7-22, 7-25
 - board specification*, 7-23
 - bus definition*, 7-23
 - derivative definition*, 7-22, 7-29
 - memory definition*, 7-23, 7-31
 - processor definition*, 7-23, 7-37
 - section layout definition*, 7-24, 7-33
- linker script language (LSL), 7-8, 7-20
 - external memory*, 7-31
 - internal memory*, 7-29
 - off-chip memory*, 7-31
 - on-chip memory*, 7-29
- linking process, 7-4
 - linking*, 7-6
 - locating*, 7-7
 - optimizing*, 7-9
- LM_LICENSE_FILE, 1-16
- local label override, 4-30
- lookup table, 3-44
- loop transformations, 5-7
- lsl, 7-20

M

- macro, 4-4
 - argument concatenation*, 4-27
 - argument operator*, 4-27
 - argument string*, 4-29
 - call*, 4-25
 - conditional assembly*, 4-31
 - definition*, 4-24

- dup directive*, 4-31
- local label override*, 4-30
- return decimal value operator*, 4-28
- return hex value operator*, 4-29
- macro argument string, 4-29
- macro operations, 4-24
- macros, 4-24
- macros in C, 3-28
- make utility, 8-9
 - .DEFAULT target*, 8-14
 - .DONE target*, 8-14
 - .IGNORE target*, 8-14
 - .INIT target*, 8-14
 - .PRECIOUS target*, 8-15
 - .SILENT target*, 8-14
 - .SUFFIXES target*, 8-14
 - conditional processing*, 8-21
 - dependency*, 8-13
 - else*, 8-21
 - endif*, 8-21
 - exist function*, 8-21
 - export line*, 8-22
 - functions*, 8-20
 - ifdef*, 8-21
 - ifndef*, 8-21
 - implicit rules*, 8-16
 - invocation*, 8-11
 - macro definition*, 8-11
 - macro MAKE*, 8-18
 - macro MAKEFLAGS*, 8-18
 - macro PRODDIR*, 8-18
 - macro SHELLCMD*, 8-19
 - macro TMP_CCOPT*, 8-19
 - macro TMP_CCPROG*, 8-19
 - makefile*, 8-9, 8-12
 - match function*, 8-20
 - nexist function*, 8-21
 - options (overview)*, 8-11
 - predefined macros*, 8-18
 - protect function*, 8-20
 - rules in makefile*, 8-15
 - separate function*, 8-20

special targets, 8-14
 makefile, 8-9
 automatic creation of, 2-13
 updating, 2-13
 writing, 8-12
 memory definition, 7-23, 7-31
 memory qualifiers, 3-10
 __a0, 3-10
 __a1, 3-10
 __a8, 3-10
 __a9, 3-10
 __atbit(), 3-13, 3-14
 __far, 3-10
 __near, 3-10
 MISRA C, 5-16
 mktc. *See* make utility
 Motorola S-record format, 7-8

N

node-locked license, 1-12

O

operands, 4-5
 optimizations, size/speed trade-off, 5-9
 optimization (backend)
 coalescer, 5-8
 IF conversion, 5-8
 instruction scheduler, 5-8
 loop transformations, 5-7
 peephole optimizations, 5-8
 predicate optimization, 5-8
 subscript strength reduction, 5-7
 use of SIMD instructions, 5-8
 optimization
 backend, 5-5
 compiler, common subexpression elimination, 5-6
 frontend, 5-4

optimization (frontend)
 conditional jump reversal, 5-7
 constant propagation, 5-6
 control flow simplification, 5-7
 dead code elimination, 5-7
 expression simplification, 5-6
 flow simplification, 5-7
 forward store, 5-7
 inlining functions, 5-7
 jump chaining, 5-7
 switch optimization, 5-7
 optimizations
 compiler, 5-5
 copy table compression, 7-10
 delete duplicate code sections, 7-10
 delete duplicate constant data, 7-10
 delete unreferenced sections, 7-10
 delete unreferenced symbols, 7-10
 first fit decreasing, 7-9

P

pack pragma, 3-9
 packed data types, 3-8
 halfword packing, 3-8
 parser, 5-4
 peephole optimization, 5-5, 5-8
 pipeline scheduler, 5-5
 Pragma
 section, 3-42
 section all, 3-42
 section code_init, 3-43
 section const_init, 3-43
 section data_overlay, 3-43
 section vector_init, 3-43
 pragmas, 3-25
 inline, 3-30
 noinline, 3-30
 pack, 3-9
 smartinline, 3-30

predefined assembler symbols

- `__ASPCP__`, 4-9
- `__ASTC__`, 4-9
- `__FPU__`, 4-9
- `__MMU__`, 4-9
- `__TC2__`, 4-9

predefined macros in C, 3-28

- `__CTC__`, 3-28
- `__DOUBLE_FP__`, 3-28
- `__DSPC__`, 3-28
- `__DSPC_VERSION__`, 3-28
- `__FPU__`, 3-28
- `__SINGLE_FP__`, 3-28
- `__TASKING__`, 3-28

predefined symbols, 4-8

predicate optimization, 5-8

printf formatter, 3-46

processor, selecting a core, 5-10, 6-5

processor definition, 7-23, 7-37

project, 2-7

- add new files*, 2-12

- create*, 2-11

project file, 2-7

project space, 2-7

- create*, 2-9

project space file, 2-7

R

rebuilding libraries, 3-48

register allocator, 5-5

registers, 4-5, 4-8

relocatable object file, 7-3

- debug information*, 7-6

- header information*, 7-6

- object code*, 7-6

- relocation information*, 7-6

- symbols*, 7-6

relocation expressions, 7-7

reserved symbols, 4-8

return decimal value operator, 4-28

return hex value operator, 4-29

S

scanf formatter, 3-46

scanner, 5-4

section, 3-42

section all, 3-42

section code `_init`, 3-43

section data `_overlay`, 3-43

section layout definition, 7-24, 7-33

section names, 3-41

sections, 3-41, 4-22

- absolute*, 4-23

- activation*, 4-22

- cleared*, 4-23

- definition*, 4-22

SIMD optimizations, 5-8

software installation

- Linux*, 1-4

- UNIX*, 1-6

- Windows 95/98/XP/NT/2000*, 1-3

stack model, 3-37

startup code, 7-18

statement, 4-3

storage types. *See* memory qualifiers

string, substring, 4-11

subscript strength reduction, 5-7

substring, 4-11

switch

- auto*, 3-44

- jumptab*, 3-44

- linear*, 3-44

- lookup*, 3-44

- restore*, 3-44

switch optimization, 5-7

switch statement, 3-44

symbol, 4-8

- predefined*, 4-8

syntax of an expression, 4-10

system call, 3-34

T

temporary files, setting directory, 1-10
trap function, 3-31
trap identification number, 3-33
trap service routine, 3-31, 3-33
trap service routine class 6, 3-34

U

updating makefile, 2-13

utilities

archiver, 8-23
artc, 8-23
cctc, 8-4
control program, 8-4
make utility, 8-9
mktc, 8-9

V

verbose option, linker, 7-17



INDEX